



COPPER-THERM

Details

CUAD
6.501

COPPER RISER DETAIL

3.14.07

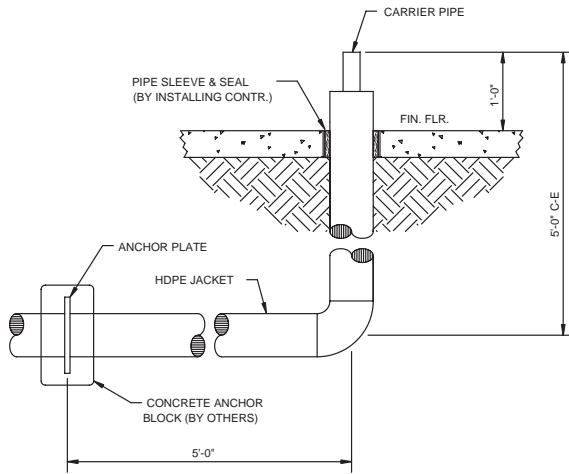

ELEVATION

PIPING RISER DETAIL
SCALE: NONE

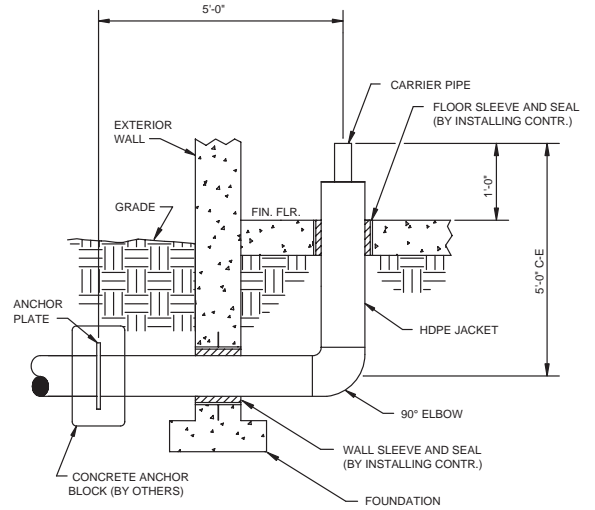

ELEVATION

BUILDING RISER DETAIL
SCALE: NONE

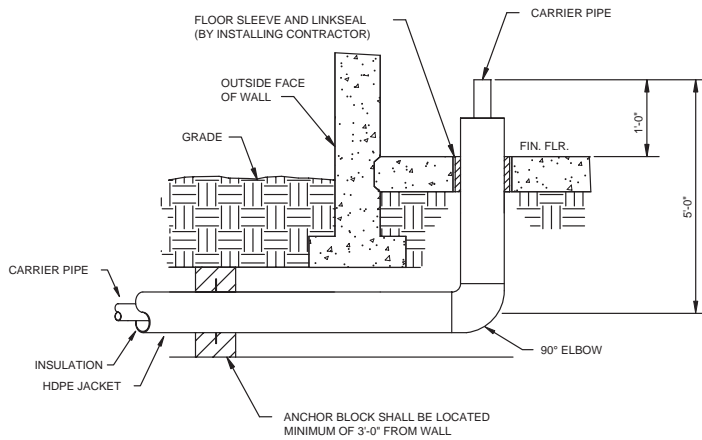

BUILDING RISER DETAIL
SCALE: NONE

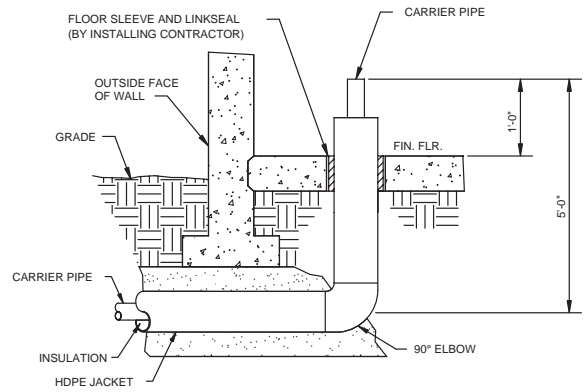

ELEVATION

BUILDING RISER DETAIL
SCALE: NONE

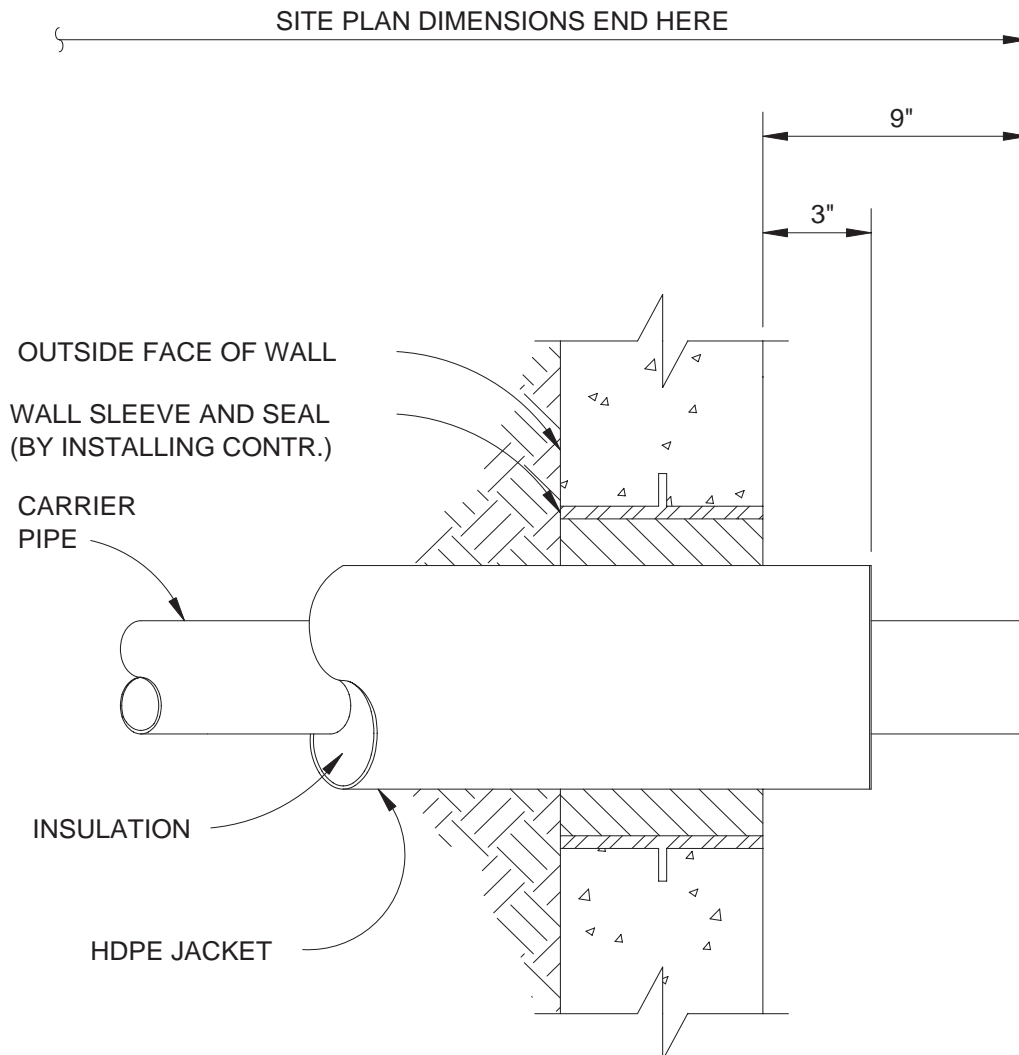

WALL PENETRATION DETAIL

SCALE: NONE

INSTALLATION INSTRUCTIONS:

EXPANSION BOLSTERS PROCEDURE

1. EXPANSION BOLSTER MATERIAL IS SUPPLIED IN PADS:
6'-0" LONG x 3" THICK x HEIGHT SPECIFIED ON CHART.
4'-0" LONG x 1" THICK x HEIGHT SPECIFIED ON CHART.
2. PLACE BOLSTER PADS AGAINST JACKET AND CURVE AROUND ELBOW AS SHOWN. HOLD IN PLACE BY ATTACHING PADS TO JACKET WITH DUCT TAPE OR EQUIVALENT ON TOP AND BEDDING SAND ON THE BOTTOM. BE CERTAIN THAT THE BOLSTER PADS FITS SNUG TO JACKET.
3. BOLSTER PAD CONFIGURATION IS DEPENDENT ON LAYOUT & WILL BE SHOWN ON THE INSTALLATION DRAWING.

PVC JACKET OD (INCHES)	HDPE JACKET OD (INCHES)	PAD HEIGHT (INCHES)
3	—	7
4	5.40	7
6	6.68	7
8	8.68	7
10	10.85	13
12	12.85	13
14	14.1	13
16	16.1	17
—	18.2	17
—	20.28	17
—	22.2	25
—	24.38	25
—	28.25	25

SCALE: NONE

*** NOTE:**

DUCT TAPE TO BE 1'-0" ON CENTERS.

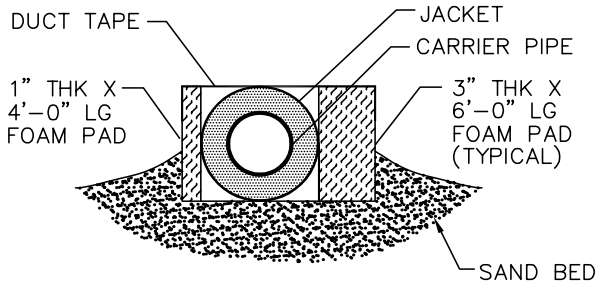

CROSS SECTION

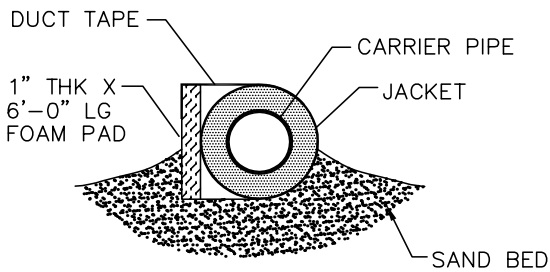
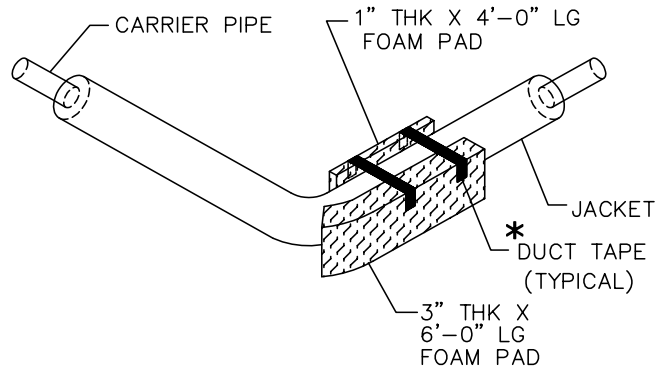

CROSS SECTION

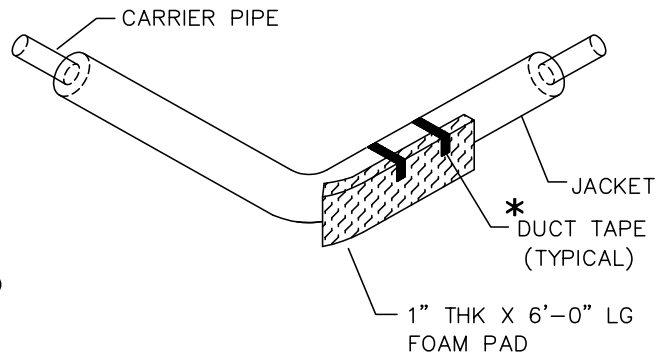

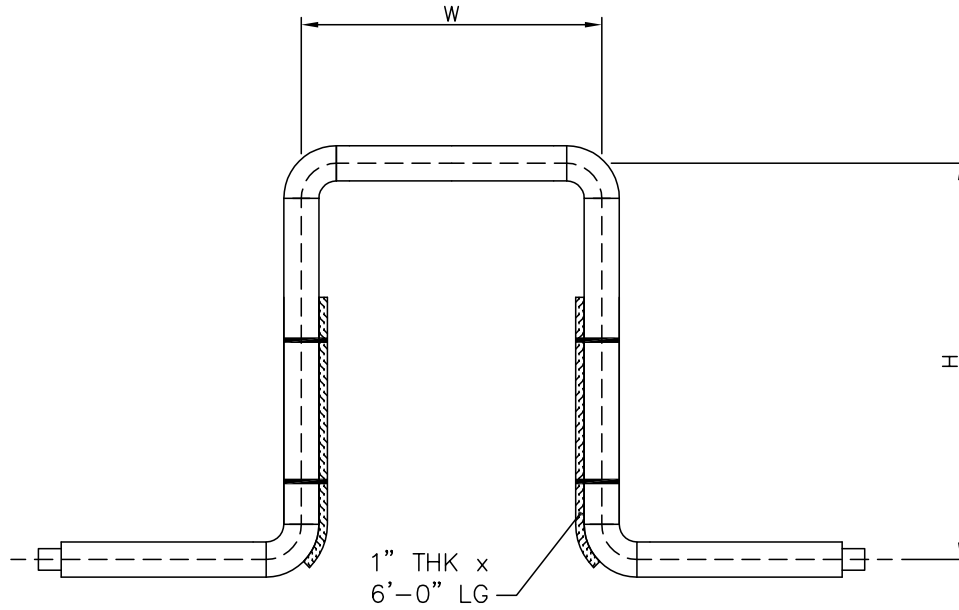

(1- PAD VIEW)

EXPANSION LOOP DETAIL

SCALE: NONE

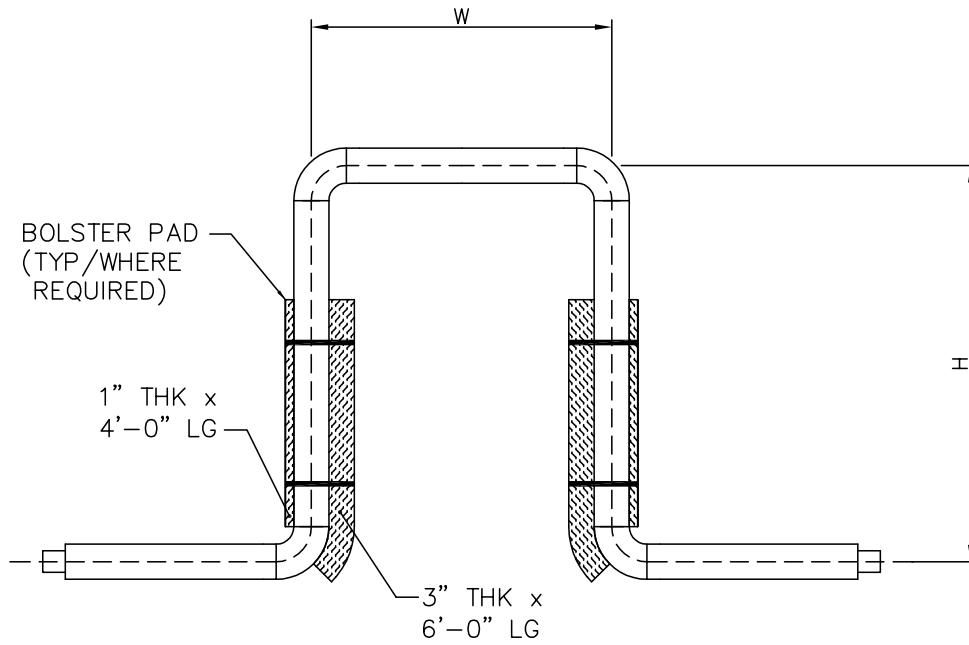

(2- PAD VIEW)

EXPANSION LOOP DETAIL

SCALE: NONE

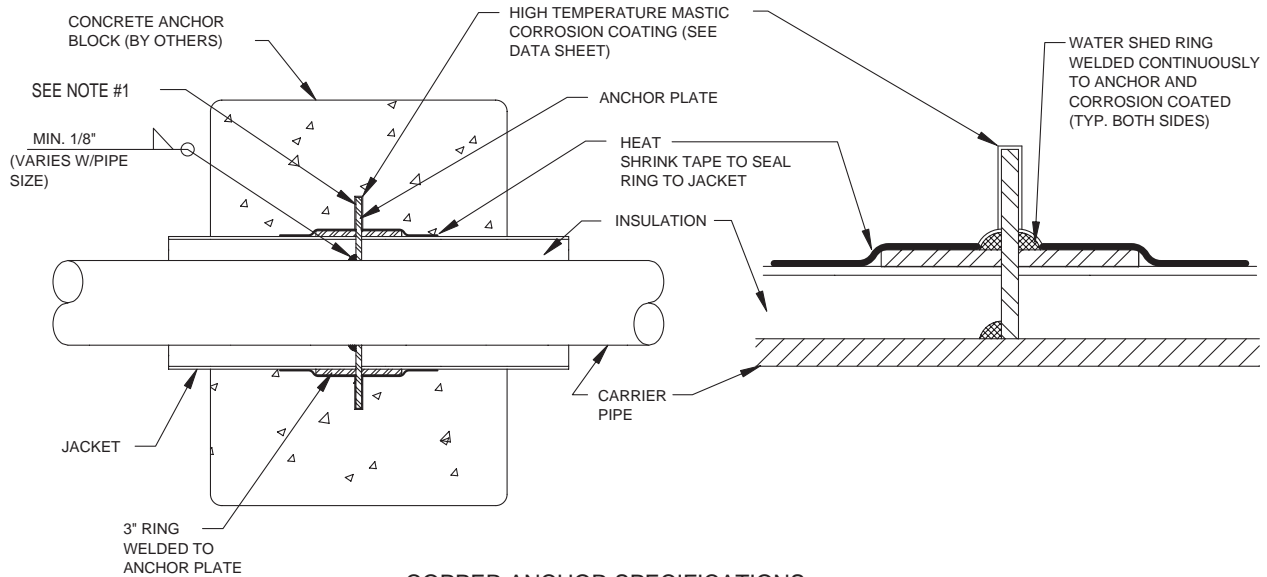

COPPER ANCHOR SPECIFICATIONS

1. BRASS ANCHOR PLATE AND WELDED RINGS FURNISHED BY THERMACOR. ANCHOR PLATE SHALL ON ALL SIZES SHALL BE 1/4" THICK. ANCHOR PLATE SHALL EXTEND 2-1/2" BEYOND THE CASING DIAMETER ON ALL SIDES. ANCHOR PLATE SHALL BE CORROSION COATED WITH A HIGH TEMPERATURE MASTIC MATERIAL AFTER WATERSHED RINGS HAVE BEEN SEALED TO CASING BY HEAT SHRINK TAPE.
2. ANCHOR ASSEMBLY SHALL BE POURED IN A CONCRETE BLOCK BY THE CONTRACTOR IN THE FIELD. GENERALLY, THE ANCHOR BLOCK EXTENDS 12" IN ALL DIRECTIONS FROM THE ANCHOR AND RESTS ON UNDISTURBED EARTH. THE JOB SITE CONDITIONS SHALL BE THE FINAL DETERMINING FACTOR FOR ANCHOR BLOCK SIZING.

PIPING ANCHOR DETAIL

SCALE: NONE



COPPER-THERM

Details

CUAD

6.506

COPPER 4 PIPE TRENCH DETAIL

3.14.07

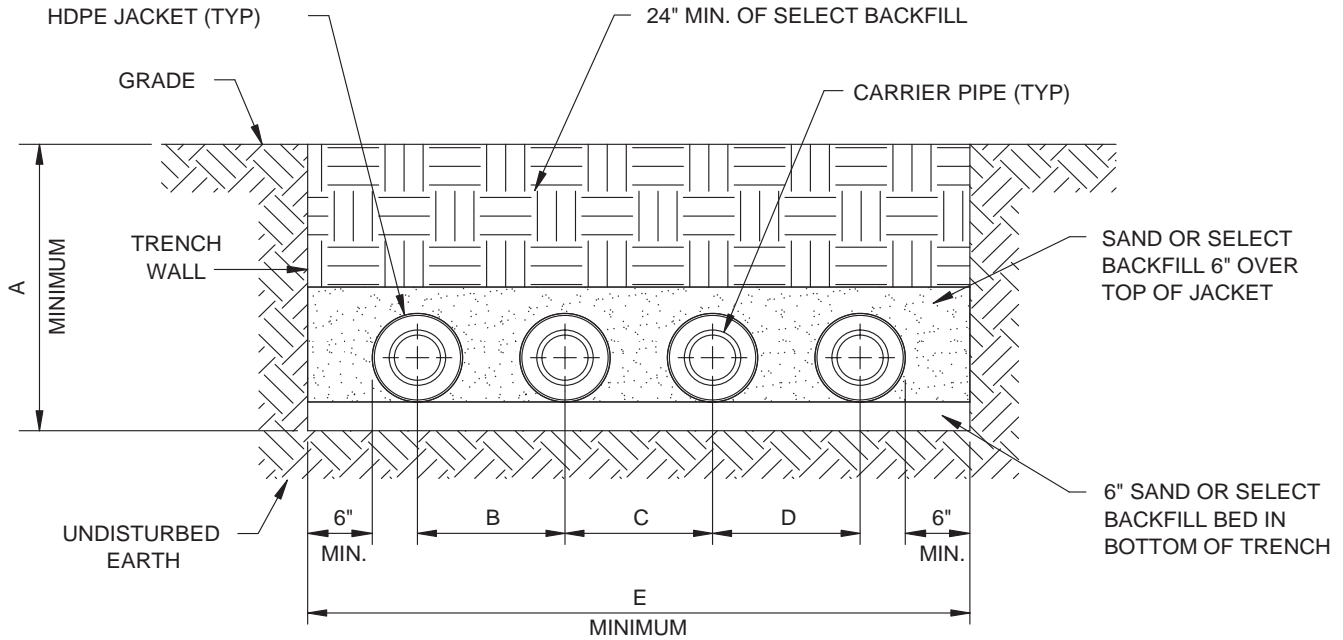

4-PIPE TRENCH SECTION

SCALE: NONE