

FERRO-THERM D.I.

DUCTILE IRON PIPING SYSTEM



FERRO-THERM D.I.

THERMACOR'S FERRO-THERM D.I. is a factory-fabricated, pre-insulated piping system for below or above ground distribution of chilled water or domestic hot water. The system is designed with a Ductile Iron steel carrier pipe, closed cell polyurethane foam insulation, and a High Density Polyethylene (HDPE) jacket.

Carrier Pipe

- Class 50, Ductile Iron w/ EPDM Gaskets
- Class 51, Ductile Iron w/ EPDM Gaskets (4")

Polyurethane Insulation

- Density
- "K" Factor
- Compressive Strength
- Closed Cell Content

Jacket

- High Density Polyethylene (HDPE)

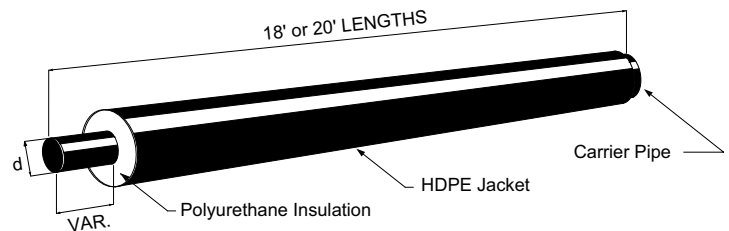

- > 2.0 lbs/ft³
- ≤ 0.18 Btu-in/hr-ft²-°F @ 75°F
- > 30 psi
- ≥ 90% @ 75°F

SPECIFICATION GUIDE *

GENERAL

All underground and above ground piping materials transporting chilled water or domestic hot water shall be **FERRO-THERM D.I.** as manufactured by **THERMACOR PROCESS INC.** All straight pipe, fittings, anchors, insulating materials, and technical support shall be provided by the manufacturer.

SERVICE PIPE

The carrier or service pipe shall be ductile iron, pressure or special class as specified, in nominal lengths standard to the industry for the specified product. Pipe and fittings shall contain an internal cement lining and be coated inside and out with a bitumastic seal coat. Systems operating over 140°F shall not be coated internally. Pre-insulated pipe sections shall be insulated from the bell end to just short of the spigot insertion stop mark. Joints shall be bell and spigot, push-on type, with SBR gaskets for cold applications, or EPDM gaskets for applications operating over 160°F. Mechanical or restrained joints may be used if required by the project. Maximum operating temperature with EPDM gaskets is 250°F.

INSULATION

Insulation of the service pipe shall be rigid polyurethane foam with a minimum 2.0 lbs/ft³ density, 90% minimum closed cell content, a "K" factor not higher than .18 (Btu-in/hr-ft²-°F) at 75°F per ASTM C518, and shall be CFC-free. The polyurethane foam shall completely fill the annular space between the service pipe and jacket, and shall be bonded to both. Insulation shall be provided to the minimum insulation thickness specified within manufacturing tolerances.

JACKET

The outer protective jacket shall be extruded, black, high density polyethylene (HDPE). No FRP, HDUP, or tape jacket allowed.

FITTINGS

Fittings shall be ductile iron with gasket joint similar to that of the ductile iron pipe. Push-on and mechanical-joint style fittings are not insulated and concrete thrust blocks are poured at all changes of direction. *Thrust block design and sizing is the responsibility of the design engineer.* Restrained-joint fittings, when used with restrained-joint piping, are not to be thrust blocked and may be insulated with flexible urethane foam insulation, jacketed and then wrapped with polyethylene backed, pressure sensitive rubberized bitumen adhesive tape, 30 mils thick.

FIELD JOINTS

Service pipe shall be hydrostatically tested as per the Engineer's specification with a factory recommendation of 1.5 times the specified pressure of the system. Joints for D.I. pipe sections are push-on, mechanical, or restrained-joint type straight field. At the Engineer's option, joints may be jacketed with a split-sleeve and sealed with a heat shrink sleeve to prevent the ingress of moisture or debris. All jacketing materials shall be furnished by THERMACOR.

INSTALLATION

Installation of the piping system shall be in accordance with the manufacturer's instructions. Factory trained field technicians shall be provided for critical periods of installation, unloading, field joint instruction, and testing.

* For alternate specifications, please contact THERMACOR.

THERMACOR PROCESS INC. Your Authorized THERMACOR Representative Is:

1670 Hicks Field Road East
Fort Worth, Texas 76179-5248
P.O. Box 79670

Phone (817) 847-7300
Fax (817) 847-7222
www.thermacor.com

The information contained in this document is subject to change without notice. THERMACOR PROCESS INC. believes the information contained herein to be reliable, but makes no representations as to its accuracy or completeness.

THERMACOR PROCESS INC. sole and exclusive warranty is as stated in the Standard Terms and Conditions of Sale for these products. In no event will THERMACOR PROCESS INC. be liable for any direct, indirect, or consequential damage.



FERRO-THERM D.I.

Specification Guide

DISG
8.101

STANDARD SPECIFICATION

2.05.2021

Pre-insulated Ductile Iron Piping Systems suitable for Chilled Water and Heating Hot Water distribution piping

Part 1 – General

1.1 Pre-insulated Piping - Furnish a complete system of factory pre-insulated Ductile Iron piping for the specified service. All pre-insulated pipe, fittings, insulating materials, and technical support shall be provided by the Pre-insulated Piping System manufacturer.

1.2 The system shall be **FERRO-THERM D.I.** manufactured by **Thermacor Process Inc.** of Fort Worth Texas.

Part 2 – Products

2.1 Carrier pipe shall be Ductile Iron, Pressure or Special Class as specified, in nominal lengths standard to the industry for the specified product. Pipe and fittings shall contain an internal cement lining and be coated inside and out with a bitumastic seal coat. Systems operating over 140°F shall not be coated internally. Pre-insulated pipe sections shall be insulated from the bell end to just short of the spigot insertion stop mark. Joints shall be bell and spigot, push-on type, with SBR gaskets for cold applications, or EPDM gaskets for applications operating over 140°F. Mechanical or restrained joints may be used if required by the project. Maximum operating temperature with EPDM gaskets is 250°F.

2.2 Insulation shall be polyurethane foam either spray applied or injected with one shot into the annular space between carrier pipe and jacket, and shall be bonded to both. Insulation shall be rigid, 90-95% closed cell polyurethane with a 2.0 to 3.0 pounds per cubic foot density and coefficient of thermal conductivity (K-Factor) of 0.18 and shall conform to ASTM C-591. Maximum operating temperature shall not exceed 250°F. Insulation thickness shall be specified by calling out appropriate carrier pipe and jacket size combinations as listed on drawing DISG 8.103.

2.3 Jacketing material shall be extruded, black, high density polyethylene (HDPE), having a wall thickness not less than 100 mils for jacket sizes less than or equal to 12", 125 mils for jacket sizes larger than 12" to 24", and 150 mils for jacket sizes greater than 24". No tape jacket allowed. The inner surface of the HDPE jacket shall be oxidized by means of corona treatment, flame treatment (patent pending), or other approved methods. This will ensure a secure bond between the jacket and foam insulation preventing any ingress of water at the jacket/ foam interface.

2.4 Straight run joints are push-on, mechanical, or restrained-joint type straight field joints. At the Engineer's option, joints may be jacketed with a split sleeve and sealed with heat shrink tape to prevent the ingress of water or debris.

2.5 Fittings shall be Ductile Iron with gasket joint similar to that of the ductile iron pipe. Push-on and mechanical-joint style fittings are not insulated and concrete thrust blocks are poured at all changes of direction. *Thrust block design and sizing is the responsibility of the design engineer.* Restrained-joint fittings, when used with restrained-joint piping, shall be thrust blocked and may be insulated with flexible urethane foam insulation, jacketed and wrapped with polyethylene backed, pressure sensitive rubberized bitumen adhesive tape, 30 mils thick.

Part 3 – Execution

3.1 Underground systems shall be buried in a trench of not less than two feet deeper than the top of the pipe and not less than eighteen inches wider than the combined O.D. of all piping systems. A minimum thickness of 24 inches of compacted backfill over the top of the pipe will meet H-20 highway loading.

3.2 Trench bottom shall have a minimum of 6" of sand as a cushion for the piping. Pipe and fittings shall be laid sequentially, field cutting the pipe as necessary per the manufacturer's installation instructions. At least 75% of each section of pre-insulated pipe shall be covered (approximately one foot of cover per 100 psi of test pressure) with select backfill material. All fittings shall be suitably thrust blocked before attempting any pressure tests of the system.

(Continued)



FERRO-THERM D.I.

Specification Guide

DISG

8.102

STANDARD SPECIFICATION

2.05.2021

3.3 A hydrostatic pressure test of the carrier pipe shall be performed per the engineer's specification with a factory recommendation of one and one-half times the normal system operating pressure for not less than two hours. Care shall be taken to insure all trapped air is removed from the system prior to the test. *Appropriate safety precautions shall be taken to guard against possible injury to personnel in the event of a failure.*

3.4 Field service, if required by project specifications, will be provided by a certified manufacturer's representative or company field service technician. The technician will be available at the job to check unloading, storing, and handling of pipe, joint installation, pressure testing, and backfilling techniques. This service will be added into the cost as part of the project technical services required by the pre-insulated pipe manufacturer.



FERRO-THERM D.I.

Specification Guide

DISG
8.103

POLYURETHANE FOAM IN HDPE JACKET

2.05.2021

Carrier Pipe:

- Class 50, Ductile Iron w/ EPDM Gaskets
- Class 51, Ductile Iron w/ EPDM Gaskets (3" & 4")
- Note: 3" DI has a long lead time.

Jacketing Material:

High Density Polyethylene (HDPE)

Insulation:

Polyurethane Foam

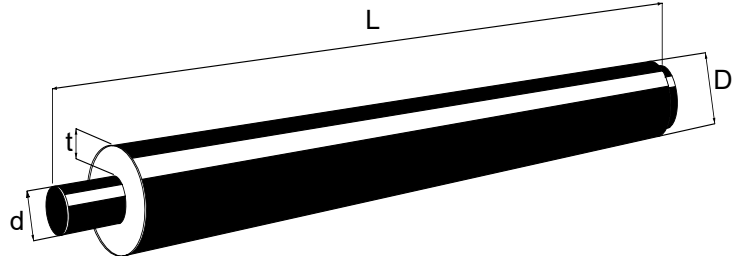

Nominal Pipe Size	Pipe Size d	Jacket Size D	Standard Length L	Insulation Thickness t	Weight Per Foot (lbs.)
3"	3.96"	6.7"	18'	1.27"	11.13
		8.7"	18'	2.27"	12.10
4"	4.8"	8.7"	18'	1.84"	14.43
		10.9"	18'	2.93"	16.01
6"	6.9"	10.9"	20'	1.88"	20.55
		12.9"	20'	2.88"	21.71
8"	9.05"	12.9"	20'	1.80"	28.06
		14.1"	20'	2.40"	29.60
10"	11.10"	14.1"	20'	1.38"	36.51
		16.1"	20'	2.38"	38.69
12"	13.20"	16.1"	20'	1.33"	46.27
		18.3"	20'	2.43"	48.23
14"	15.30"	18.3"	20'	1.38"	57.24
		20.3"	20'	2.38"	60.60
16"	17.40"	20.3"	20'	1.33"	67.94
		22.2"	20'	2.28"	70.23
18"	19.50"	22.2"	20'	1.23"	77.71
		24.4"	20'	2.30"	80.35
20"	21.60"	24.4"	20'	1.25"	88.00
24"	25.80"	28.3"	20'	1.10"	110.88
		30.6"	20'	2.25"	114.92

* Other sizes are available.
 ** Other lengths available based on D.I. pipe manufacturer.
 *** Restraint joint available.
 **** Standard HDPE wall thickness



FERRO-THERM D.I.

Installation Manual

DIIM
8.201

GENERAL INSTALLATION INSTRUCTIONS

2.08.2021

INSTALLATION INSTRUCTIONS

UNLOADING & HANDLING

Lift joints from trucks. DO NOT DROP SHARP OR HEAVY OBJECTS ON INSULATED UNITS. DO NOT use chains or other devices which might puncture insulation jacket.

STORAGE

Pipe is stockpiled off the ground. Do not exceed a stacking height of 6'. Prevent dirt and debris from entering pipe. Fittings, joining materials, etc. must be stored indoors to protect them from freezing, overheating, moisture, or loss.

LAYING OF PIPE UNITS – TRENCHING

All sharp rocks, roots, and other abrasive material must be removed from the trench. The trench bed should be 6" of sand or backfill as specified by the engineer, providing a smooth and uniform stabilizing surface (sandbags may be used as a means to keep the pipe off the ground until backfilling is started). The trench width should provide a minimum of 6" from trench wall to jacket O.D. and a minimum of 6" between pipe units. Trench depths will be indicated on the contract drawing and in line with good construction practices. Trench depth should allow for a minimum cover of 24" on top of the insulated unit.

FIELD JOINING METHODS

Clean pipe ends and coupling groove to ensure proper gasket sealing. Insert rubber gasket into bell groove, making certain gasket is seated in groove and facing the correct direction (see manufacturer's brochure). Lubricate pipe ends and the gasket with Thermacor provided lubricant. Insert lubed spigot straight into bell to first stop mark using block and bar or puller. DO NOT GO PAST THE STOP MARK. DO NOT USE PETROLEUM BASED LUBRICANTS!

FIELD ALTERATIONS

Pipe will be cut in the field, based on the appropriate field measurements for fittings and/ or making manhole or wall entries, unless the system is pre-engineered with piece mark sections. If special short pieces are required, measure distance needed for field alteration and cut through unit with saw. Pipe manufacturer may provide special field cut lengths of pipe which will be marked with colored ends and should be used for all short pieces when available. Using factory insulated pipe as guide, cut back insulation and bevel pipe (simultaneously removing burrs, cuts, nicks, and scratches). Apply end seals to the clean, dry, exposed insulation surface. Stop marks must be indicated on any cut back pieces. Using a factory finished end as an example, make a stop mark on the spigot using a crayon or pencil. DO NOT OVER BELL PIPE.

BACKFILL INITIAL

After pipe is installed, sand shall be tamped around the conduit in 6" layers to insure proper compaction. One foot on either side of each joint and fitting shall be left bare for visual inspection during testing.

HYDROSTATIC TESTING

Sufficient backfill must be placed on pipe and thrust blocks poured and cured, prior to testing. Temporary thrust blocks should be used with caution to proof test joints in pipe and fittings. Bleed all air from lines to eliminate possible incorrect readings. The hydrostatic pressure test shall be performed per the engineer's specification with a factory recommendation of one and one-half times the normal operating pressure for not less than two hours. Inspect all fittings, valves, and couplings at this time. *Appropriate safety precautions shall be taken to guard against possible injury to personnel in the event of a failure.*

BACKFILL FINAL

After testing is complete, a minimum of 12" of specified backfill is hand tamped over the top of the insulated unit. Backfilling is completed using standard backfill material and machines, taking care to eliminate large rocks (6" in diameter or greater), boulders, stumps, foreign matter, or frozen earth.

WHEELED OR TRACKED VEHICLES SHALL NOT BE USED FOR TAMPING!

THRUST BLOCK INSTALLATION

The engineer who designs the system has the responsibility for designing and sizing the thrust blocks. A knowledge of site soil conditions is essential for proper design. Thermacor will not accept or assume responsibility for thrust blocks, and intends to provide basic data only.

WHY THRUST BLOCKS?

A Ferro-Therm D.I. system must include thrust blocks to prevent any rubber gasketed joints from separating under pressure. To prevent separation, thrust blocks must be located at:

1. All major changes in direction; i.e., tees and elbows (both horizontal and vertical).
2. All changes in size.
3. All terminal ends.
4. All Valves, so as to support the body weight and prevent excessive torque on pipe connections.
5. IMPORTANT: Any connecting metallic pipe must be anchored at the point of connection to the D.I. pipe to prevent excessive stresses from being transferred to the D.I. pipe.

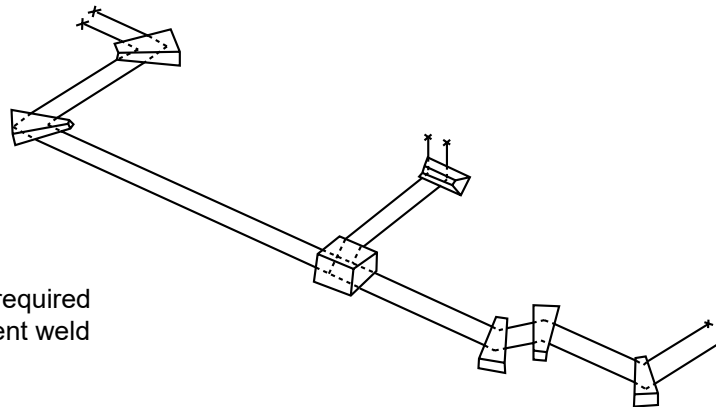

NOTE: Thrust blocks are required with gasket pipe and solvent weld fittings.

INSTALLATION

As thrust blocks are an essential part of the system, they should be poured before hydrostatic testing. Temporary thrust blocking may be used with extreme caution if absolutely necessary. The system must be retested after the permanent thrust blocks are poured and cured to verify that the thrust blocks will resist the thrust.

DESIGN

The design of the thrust blocks depends on test pressure, size, number of pipes, soil conditions, and types of fittings involved. Three conditions must be met for the thrust blocks to function properly.

1. The bearing area must be adequate to resist the pressure force.
2. The bearing surface must rest directly against undisturbed soil.
3. The face of the block bearing surface in the soil must be perpendicular to the resultant direction of thrust.

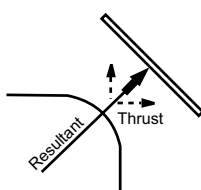

90° ELBOW

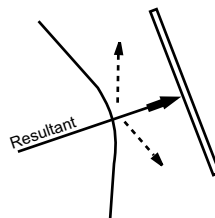

45° ELBOW

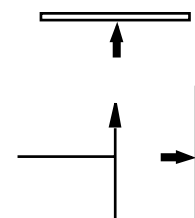

REDUCING TEE

If the thrust blocks have not been designed by the engineer, they must be sized by the following procedure:
Example: Design a thrust block to resist the horizontal thrust of two 4" chilled water lines (supply and return) at a 90° elbow. The test pressure is 150 psi and the soil is soft clay.

TABLE 1 POUNDS OF THRUST AT FITTING FOR 100 POUNDS/ SQ. INCH OPERATING PRESSURE				TABLE 2 SAFE BEARING LOADS	
PIPE SIZE	TEE	90°	45°	SOIL	LB. PER SQ. FT.
3"	1,395	1,900	1,160	Muck, Peat	0
4"	1,950	2,700	1,550	Soft Clay	1,000
6"	3,950	5,600	3,050	Sand	2,000
8"	6,750	9,500	5,100	Sand & Gravel	3,000
10"	10,900	15,450	9,400	Sand & Gravel cemented with clay	4,000
12"	15,550	29,600	11,900	Hard Shale	10,000
14"	21,000	31,850	16,100		
16"	27,300	38,400	31,000		
18"	35,200	49,500	27,000		
20"	43,500	61,100	33,300		
24"	62,400	89,900	47,900		

STEP 1 FINDING THRUST:

From Table 1, the resultant thrust of a 4" x 90° elbow is 2700 lbs. at 100 psi.

At 150 psi, the thrust is:

$$2700 \text{ lbs.} \times \frac{150 \text{ psi}}{100 \text{ psi}} = 4050 \text{ lbs. elbow}$$

4050 lbs. x 2 = 8100 lbs. thrust for two elbows.

STEP 2 FINDING BEARING AREA OF BLOCK:

From Table 2, soft clay has a bearing strength of 1000 lbs./ sq. ft. therefore:

$$\frac{8100 \text{ lbs.}}{1000 \text{ lbs./ sq. ft.}} = 8.1 \text{ sq. ft. bearing area required}$$

or a block face of 4' x 2' (8 sq. ft.) is adequate.

THRUST BLOCK TYPES

Examples of thrust blocks for normal fittings are illustrated.

For vertical risers the trench bottom must be undercut and the entire trench bottom should be covered with concrete.

The thrust blocks must bear against firm, stable soil.

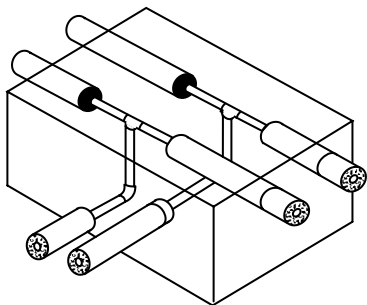

FIGURE II

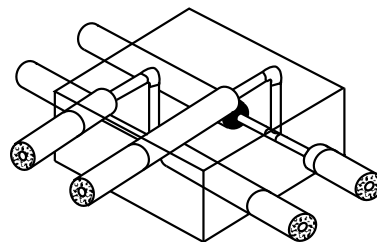

FIGURE I

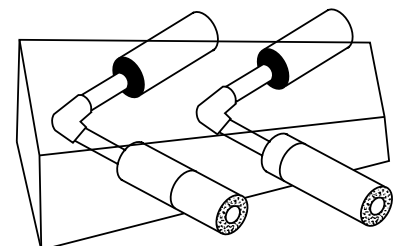

FIGURE III

CONSTRUCTION

Thrust blocks are made of concrete.

An acceptable concrete is 1 part Portland cement, 2 parts washed sand, and 3 parts washed gravel with enough water for a relatively dry mix. The dry mix is easier to shape and offers higher strength.

The concrete should be worked thoroughly around the elbows for maximum surface contact. Make sure the entire area between the fittings and the trench wall is filled with concrete and free of voids.

The blocks should be shaped with the designed bearing area against the trench wall. Smaller blocks should be shaped by hand. Larger blocks require simple forms.

The trench should be undercut under the pipes at least six inches to give added thrust resistance and to provide adequate concrete around the fittings. Six inches of concrete should be over the top of the pipe.

The center of the thrust blocks bearing surface should coincide with the horizontal center line of the pipes. (See figures I and II).

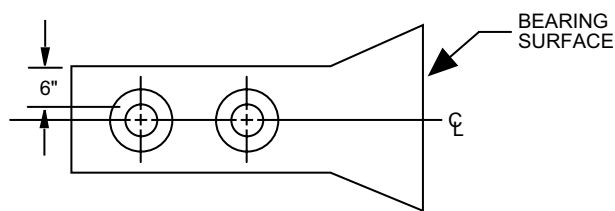

FIGURE I

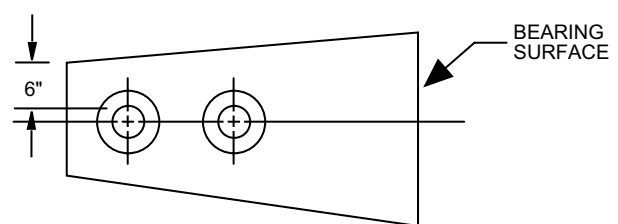

FIGURE II

UNSTABLE SOIL

If the soil is unstable in the area of a thrust block, it will be necessary for the engineer to make special provisions. This is considered a civil engineering matter and a project civil engineer should be consulted for professional advice.

VALVE BLOCKS

Blocks must be poured beneath valves with sufficient steel for valve connections. This supports the valve weight and prevents any torque or twisting action caused by opening and closing the valve.

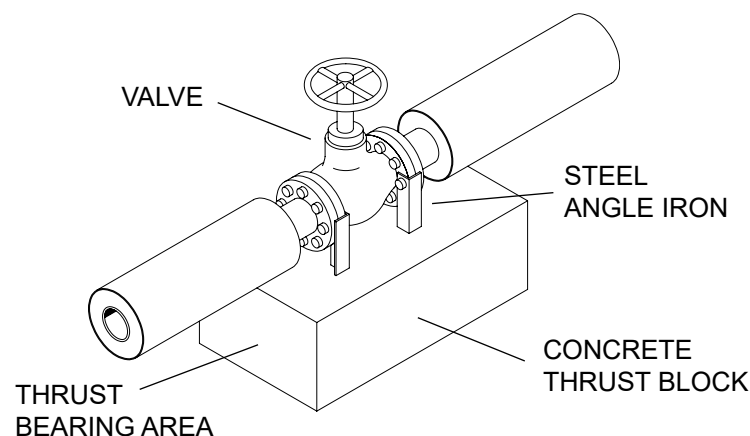

SHIPPING & HANDLING INSTRUCTIONS

HANDLE COATED PIPE WITH EXTRA CARE! THIS PIPE CAN DAMAGE WHEN HANDLED, MOVED, OR STORED IMPROPERLY!

UPON RECEIPT OF MATERIALS

Make an overall inspection of the load, checking all bands and braces to see if they are intact. Also, check the load for shifting. If the load has shifted, or if the braces and bands are broken, examine each pipe for damage. **HAVE THE TRUCK DRIVER MAKE AN ITEMIZED NOTATION OF ANY DAMAGE ON THE DELIVERY RECEIPT AND HAVE IT SIGNED BY THE DRIVER.**

CHECK PACKING LIST

Compare materials received with those listed on the packing list. Count all pipe and boxes. **NOTE ANY SHORTAGES ON DRIVER'S DELIVERY RECEIPT.**

CHECK BOXES

Open all boxes and inspect for damages, shortages, and correct size. **REPORT ANY DISCREPANCIES WITHIN 30 DAYS AFTER RECEIPT.**

CLAIMS FOR DAMAGES

Claims for damages in transit or lost goods must be made within 30 days. The filing of any claim is the Purchaser's Responsibility. Thermacor will file any claim on Purchaser's behalf upon receipt of the following:

1. Written authority to file such a claim.
2. Written notice of loss or damage (signed and noted Bill of Lading) by truck driver or carrier freight agent.

UNLOADING PIPE

Pipe may be unloaded by hand or with fork lifts*, cherry pickers, or cranes. **DO NOT HOOK** pipe ends. Minimum 4" wide straps or slings should be used.

*Fork Lift – When using Fork Lift, wide tines or a large surface covering the fork tines must be used to prevent coating damage. Fork Lift must be able to handle the weight of the insulated pipe length.

PIPE STOCKPILING

Pipe should be stored on level ground, elevated to be as dry as possible, and in such a way that the pipe ends do not lie in water or on the ground. To prevent deformation of the jacket and insulation due to the weight of the pipe, place a series of supports (3 for 20' or 5 for 40') of ample size generally constructed from 2" x 4"s under the pipe as shown below. Supports should increase in width as weight load increases so that the top supports of a fully loaded stockpile should be approximately 10" wide, gradually increasing to the bottom level, approximately 18" wide. Pipe can be pyramided (within reasonable and safe limits) approximately 6' high after a properly braced or chocked base is formed. Pipe stored outside for long periods of time can be covered with blue mesh tarpaulin (plywood can also be used). **Do not prevent airflow as jacket can be deformed from heat buildup.**

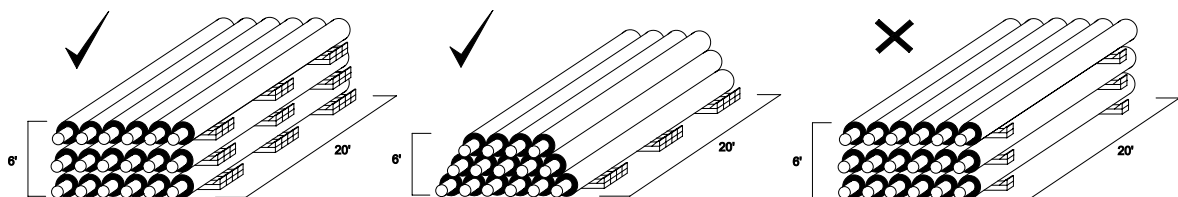

BE VERY CAREFUL NOT TO DROP THE PIPE!

NOTE: Thermacor does not approve of the practice of installing pipe and fittings, and backfilling the pipe before testing. Thermacor will not allow or pay claims for charges which arise in locating and digging up leaks regardless of cause.