

FERRO-THERM

STEEL PIPING SYSTEM



FERRO-THERM

THERMACOR'S FERRO-THERM is a factory-fabricated, pre-insulated piping system for below or above ground distribution of hot and chill water, low pressure steam, condensate, or oil and viscous fluids. The system is designed with a steel carrier pipe (type and grade specified, as required), closed cell polyurethane foam insulation, and a High Density Polyethylene (HDPE) jacket.

Carrier Pipe

- $d \geq 2"$ - A53 ERW Grade B, Std. Wt. Black Steel
- $d < 2"$ - A106 SML, Std. Wt. Black Steel
- Seamless & Schedule 80 pipe are available for all sizes.
- Std. Wt. is the same as Schedule 40 through 10".
- XS is the same as Schedule 80 through 8"

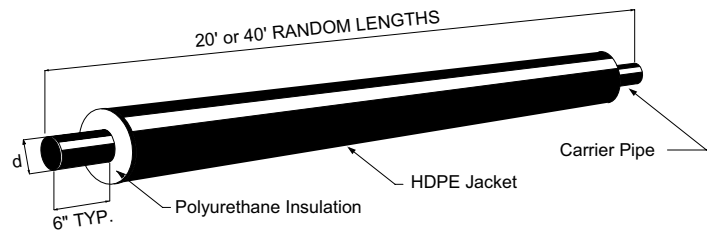

Polyurethane Insulation

- | | |
|------------------------|---------------------------|
| • Density | > 2.0 lbs/ft ³ |
| • "K" Factor | ≤ 0.18 @ 75°F |
| • Compressive Strength | > 30 psi |
| • Closed Cell Content | ≥ 90% @ 75°F |

Jacket

- High Density Polyethylene (HDPE)

SPECIFICATION GUIDE *

GENERAL

All underground and above ground piping materials transporting chill water, hot water, low-pressure steam (250°F) or condensate shall be **FERRO-THERM** as manufactured by **THERMACOR PROCESS INC.** All straight pipe, fittings, anchors, insulating materials, and technical support shall be provided by the manufacturer.

SERVICE PIPE

The carrier or service pipe shall be A-53, Grade B, ERW, Standard Weight for pipe sizes 2" and larger and A106/ A53, Grade B, seamless, standard weight for pipe sizes 1.5" and smaller. Condensate piping materials shall be extra strong. Pipe shall be butt-welded for sizes 2" and larger and socket-welded for 1.5" and smaller. Straight sections shall be supplied in 20 or 40 foot random lengths with cutbacks to allow for welding at the field joints.

INSULATION

Insulation of the service pipe shall be rigid polyurethane foam with a minimum 2.0 lbs/ft³ density, 90% minimum closed cell content, and a "K" factor not higher than .18 at 75°F per ASTM C518. The polyurethane foam shall be CFC-free. The polyurethane foam shall completely fill the annular space between the service pipe and jacket, and shall be bonded to both. Insulation shall be provided to the minimum insulation thickness specified.

JACKET

The outer protective jacket shall be high density polyethylene (HDPE). No FRP, HDUP, or tape jacket allowed.

FITTINGS

Fittings are Thermacor's SC (standard component) factory pre-fabricated and pre-insulated fittings with polyurethane foam to the thickness specified and jacketed with a one piece seamless molded HDPE fitting cover, a butt fusion welded, or an extrusion welded and mitered HDPE jacket. Carrier pipe fittings shall be butt-welded, except sizes smaller than 2" shall be socket-welded. (*At the Engineer's option*, fittings can be pre-fabricated/ pre-engineered.) Fittings include expansion loops, elbows, tees, reducers, and anchors. Elbows, loops, offsets, or any other direction changes shall conform to the standards set by ANSI B31.1, Code for Power Piping.

FIELD JOINTS

Service pipe shall be hydrostatically tested as per the Engineer's specification with a factory recommendation of 1.5 times the specified pressure of the system. Straight joint sections shall be insulated using urethane foam to the thickness specified, jacketed with an HDPE split sleeve, and sealed with a heat shrink sleeve. (*At the Engineer's option*, joints may be sealed with a pressure testable joint closures.) All joint closures and insulation shall occur at straight sections of pipe. All insulation and jacketing materials shall be furnished by THERMACOR.

INSTALLATION

Installation of the piping system shall be in accordance with the manufacturer's instructions. Factory trained field technicians shall be provided for critical periods of installation, unloading, field joint instruction, and testing.

** For alternate specifications, please contact THERMACOR.*

THERMACOR PROCESS INC. Your Authorized THERMACOR Representative Is:

1670 Hicks Field Road East
Fort Worth, Texas 76179-5248
P.O. Box 79670

Phone (817) 847-7300
Fax (817) 847-7222
www.thermacor.com

The information contained in this document is subject to change without notice. THERMACOR PROCESS INC. believes the information contained herein to be reliable, but makes no representations as to its accuracy or completeness.

THERMACOR PROCESS INC. sole and exclusive warranty is as stated in the Standard Terms and Conditions of Sale for these products. In no event will THERMACOR PROCESS INC. be liable for any direct, indirect, or consequential damage.



FERRO-THERM

Specification Guide

FTSG
7.101

STANDARD SPECIFICATION

10.01.2021

Pre-insulated HDPE-Jacketed Steel Piping Systems suitable for Chilled Water, Heating Water, Domestic Hot Water, Process Fluids, Low Pressure Steam (15 PSIG Max.), Condensate Return, and Cryogenic services.

Part 1 - General

1.1 Pre-insulated Piping - Furnish a complete HDPE jacketed system of factory pre-insulated steel piping for the specified service. All pre-insulated pipe, fittings, insulating materials, and technical support shall be provided by the Pre-insulated Piping System manufacturer.

1.2 The system shall be **FERRO-THERM** as manufactured by **Thermacor Process Inc.** of Fort Worth, Texas.

Part 2 - Products

2.1 Carrier pipe shall be steel ASTM A-53, Grade B., ERW (Type E) or seamless (Type S), standard weight for sizes 2" and larger, and shall be ASTM A-106/ A-53, seamless, standard weight for sizes 1-1/2" and smaller (Std. Wt. is the same as Sch. 40 through 10"). Condensate return piping shall be Extra Strong (XS is the same as Sch. 80 through 8"). When practical, piping shall be provided in 40-foot double-random lengths. All carbon steel pipe shall have ends cut square and beveled for butt-welding. Straight sections of factory insulated pipe shall have 6" of exposed pipe at each end for field joint fabrication.

2.2 Insulation shall be polyurethane foam either spray applied or injected with one shot into the annular space between carrier pipe and jacket. Insulation shall be rigid, 90% minimum closed cell polyurethane with a minimum 2.0 lbs per cubic foot density, compressive strength of 30 psi, and coefficient of thermal conductivity (K-Factor) of not higher than 0.18 @ 75°F per ASTM C-518. Maximum operating temperature shall not exceed 250°F. Insulation thickness shall be specified by calling out appropriate carrier pipe and jacket size combinations as listed on drawing FTSG 7.103.

2.3 Jacketing material shall be extruded, black, high density polyethylene (HDPE), having a wall thickness not less than 100 mils for jacket sizes less than or equal to 12", 125 mils for jacket sizes larger than 12" to 24", and 150 mils for jacket sizes greater than 24". No tape jacket allowed. The inner surface of the HDPE jacket shall be oxidized by means of corona treatment, flame treatment (patent pending), or other approved methods. This will ensure a secure bond between the jacket and foam insulation preventing any ingress of water at the jacket/ foam interface.

2.4 Straight run joints shall be field-insulated per the manufacturer's instructions, using polyurethane foam poured in an HDPE sleeve and sealed with heat shrink sleeve. (*At the Engineer's option*, a pressure testable joint closure may be specified.) All joint closures and insulation shall occur at straight sections of pipe. All insulation and jacketing materials shall be furnished by THERMACOR.

2.5 Fittings are Thermacor's SC (standard component) factory pre-fabricated and pre-insulated fittings with polyurethane foam to the thickness specified and jacketed with a one-piece seamless molded HDPE fitting cover, a butt fusion welded, or an extrusion welded and mitered HDPE jacket. Carrier pipe fittings shall be butt-welded, except sizes smaller than 2" shall be socket-welded. (*At the Engineer's option*, fittings can be pre-fabricated/ pre-engineered.) Fittings include expansion loops, elbows, tees, reducers, and anchors. Elbows, loops, offsets, or any other direction changes shall conform to the standards set by ASME B31.1, Code for Power Piping.

2.6 Expansion/ contraction compensation will be accomplished utilizing factory pre-fabricated and pre-insulated expansion elbows, Z-bends, expansion loops, and anchors specifically designed for the intended application. External expansion compensation utilizing flexible expansion pads (minimum one inch thickness), extending on either side, both inside and outside the radius of the fittings are used with all fittings having expansion in excess of 3/4".

(Continued)



FERRO-THERM

Specification Guide

STANDARD SPECIFICATION

FTSG

7.102

10.01.2021

Part 3 - Execution

3.1 Pre-fabricated systems shall be provided as SC (standard components) fittings and factory insulated straight pipe sections for field engineering per the contract drawings. (*At the Engineer's option, system can be pre-fabricated/pre-engineered.*)

3.2 Underground systems shall be buried in a trench not less than two feet deeper than the top of the pipe and not less than eighteen inches wider than the combined O.D. of all piping systems. A minimum thickness of 24 inches of compacted backfill placed over the top of the **pipe will meet H-20 highway loading.**

3.3 Trench bottom shall have a minimum of 6" of sand as a cushion for the piping. All field cutting of the pipe shall be performed in accordance with the manufacturer's installation instructions.

3.4 A hydrostatic pressure test of the carrier pipe shall be performed per the engineer's specification with a factory recommendation of one and one-half times the normal system operating pressure for not less than two hours. Care shall be taken to insure all trapped air is removed from the system prior to the test. *Appropriate safety precautions shall be taken to guard against possible injury to personnel in the event of a failure.*

3.5 Field Service, if required, shall be provided by a certified manufacturer's representative or company field service technician. The technician will be available at the job a minimum of one day (or more if required by job size) to check unloading, storing, and handling of pipe, pipe installation, pressure testing, field joint insulation, and backfilling techniques.



FERRO-THERM

Specification Guide

FTSG
7.103

POLYURETHANE FOAM IN HDPE JACKET

10.01.2021

Carrier Pipe:

- d ≥ 2" - A53 ERW Grade B, Std. Wt. Black Steel
- d < 2" - A106 SML, Std. Wt. Black Steel
- Seamless and Schedule 80 pipe available for all sizes
- Std. Wt. is the same as Schedule 40 for all sizes thru 10"
- XS is the same as Schedule 80 for all sizes thru 8"

Jacketing Material:

High Density Polyethylene (HDPE)

Insulation:

Polyurethane Foam

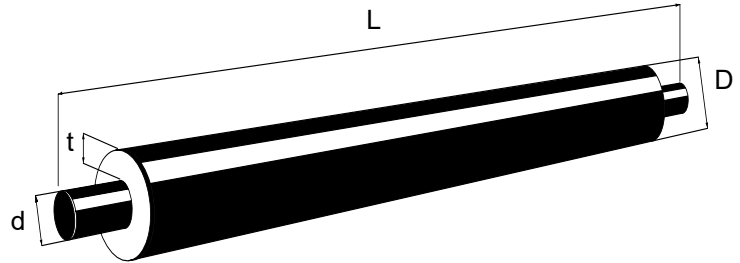

Pipe Size	Jacket Size	Standard Length L	Insulation Thickness t	Weight Per Foot (lbs.)
1/2"	5.4"	20'	2.2"	1.9
3/4"	5.4"	20'	2.1"	2.2
1"	5.4"	20'	1.9"	3.2
1-1/4"	5.4"	20'	1.8"	3.8
1-1/2"	5.4"	20'	1.7"	4.2
2"	5.4"	40'	1.4"	5.1
2-1/2"	6.7"	40'	1.8"	7.7
3"	† 5.7"	40'	1.0"	9.1
	6.7"	40'	1.5"	9.5
	8.7"	40'	2.5"	10.1
4"	6.7"	40'	1.0"	12.5
	† 7.7"	40'	1.5"	13.0
	8.7"	40'	2.0"	13.5
5"	7.7"	40'	1.0"	16.7
	8.7"	40'	1.5"	17.1
6"	† 8.9"	40'	1.0"	21.5
	† 9.9"	40'	1.5"	22.0
	10.9"	40'	2.0"	22.4
8"	† 10.9"	40'	1.0"	31.5
	† 11.9"	40'	1.5"	32.2
	12.9"	40'	2.0"	32.9
10"	† 13.0"	40'	1.0"	44.3
	14.1"	40'	1.6"	46.3
12"	† 15.0"	40'	1.0"	55.4
	16.1"	40'	1.6"	56.2
14"	† 16.2"	40'	1.0"	60.8
	† 17.2"	40'	1.5"	61.9
	18.2"	40'	2.0"	63.0

Pipe Size	Jacket Size	Standard Length L	Insulation Thickness t	Weight Per Foot (lbs.)
16"	† 18.3"	40'	1.0"	69.7
	† 19.3"	40'	1.5"	71.2
	20.3"	40'	2.0"	72.7
18"	† 20.3"	40'	1.0"	79.6
	† 21.3"	40'	1.5"	80.7
	22.3"	40'	2.0"	81.8
20"	† 22.4"	40'	1.0"	88.6
	† 23.4"	40'	1.5"	87.8
	24.4"	40'	2.0"	90.9
24"	† 26.3"	40'	1.0"	106.3
	† 27.3"	40'	1.5"	108.1
	28.3"	40'	2.0"	109.9
28"	† 30.3"	40'	1.0"	126.0
	† 31.3"	40'	1.5"	127.5
	32.3"	40'	2.0"	129.0
30"	† 32.3"	40'	1.0"	140.0
	† 33.3"	40'	1.5"	141.5
	36.6"	40'	3.2"	143.0

† Pipe/ Jacket combination available on sticks & kits only.

* Other pipe sizes and pipe and jacket combinations are available.

** Insulation thickness is calculated using minimum wall thickness. Actual wall thickness may be greater than stated, thereby minimally decreasing actual foam thickness.

HEAT LOSS FOR 1" OF POLYURETHANE FOAM*

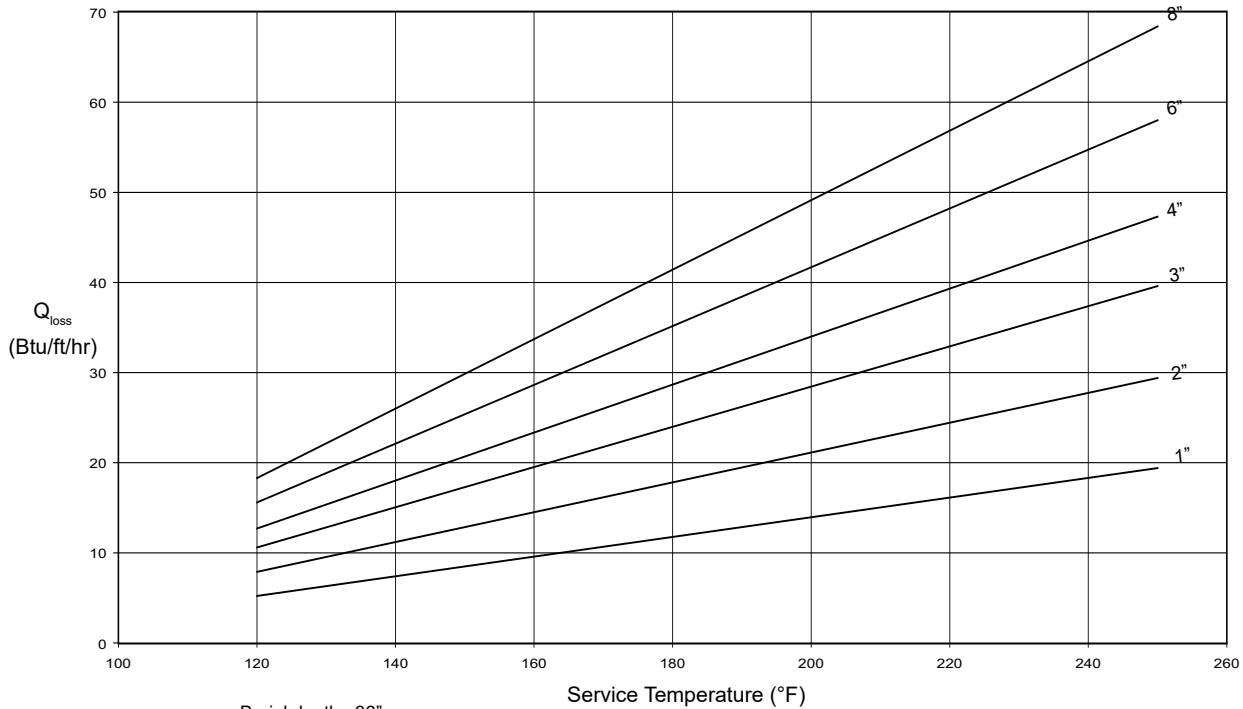

- Burial depth: 36"
- Soil conductivity: 12 (Btu/h.ft².°F/ft)
- Soil temperature: 50°F

HEAT LOSS FOR 2" OF POLYURETHANE FOAM*

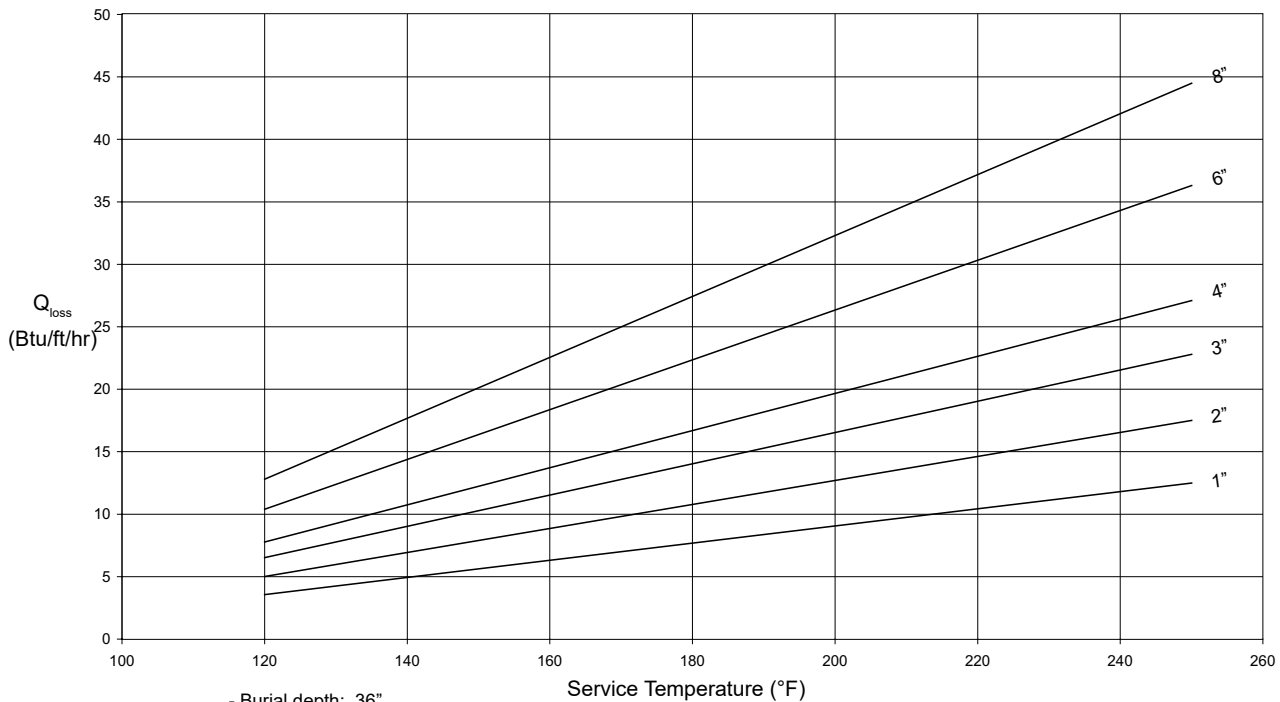

- Burial depth: 36"
- Soil conductivity: 12 (Btu/h.ft².°F/ft)
- Soil temperature: 50°F

* Values are calculated using 3E Plus in accordance with ASTM C680 and are subject to the terms and limitations stated in the software. Actual heat loss may vary.

HEAT LOSS FOR 2" OF POLYURETHANE FOAM*

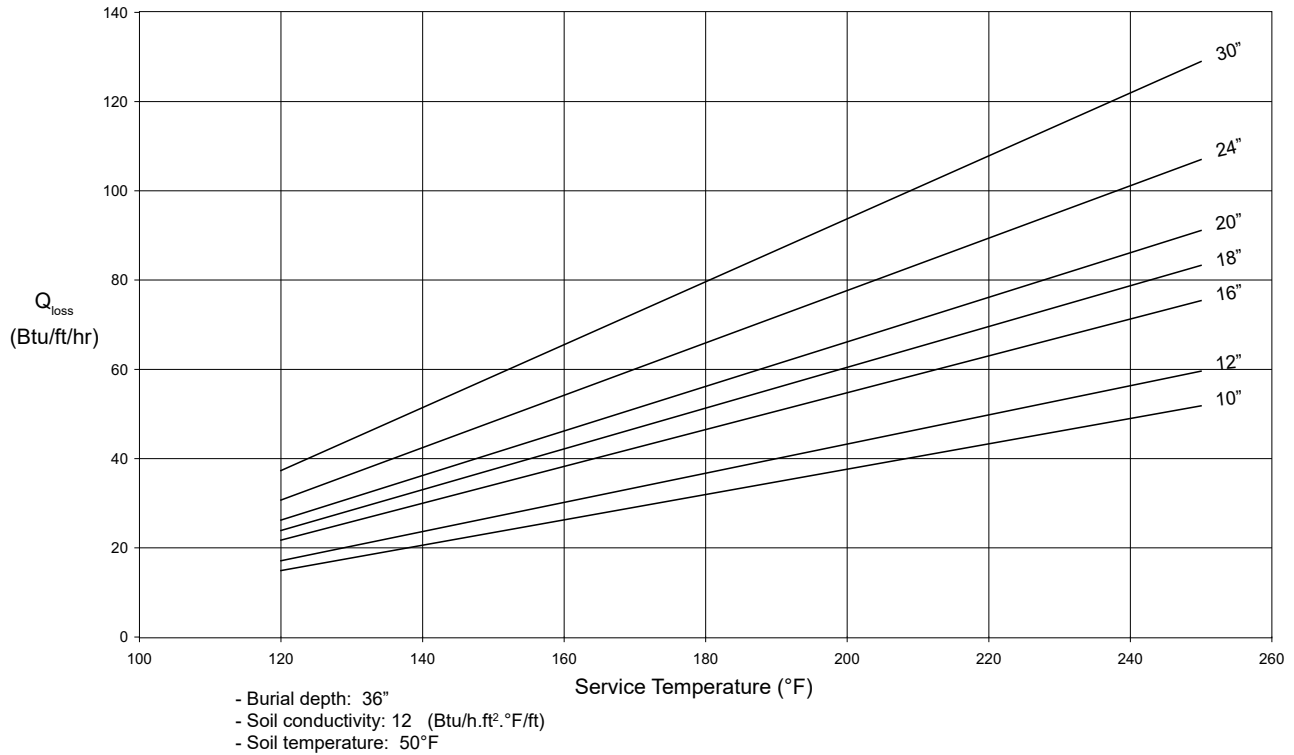

HEAT LOSS FOR 3" OF POLYURETHANE FOAM*

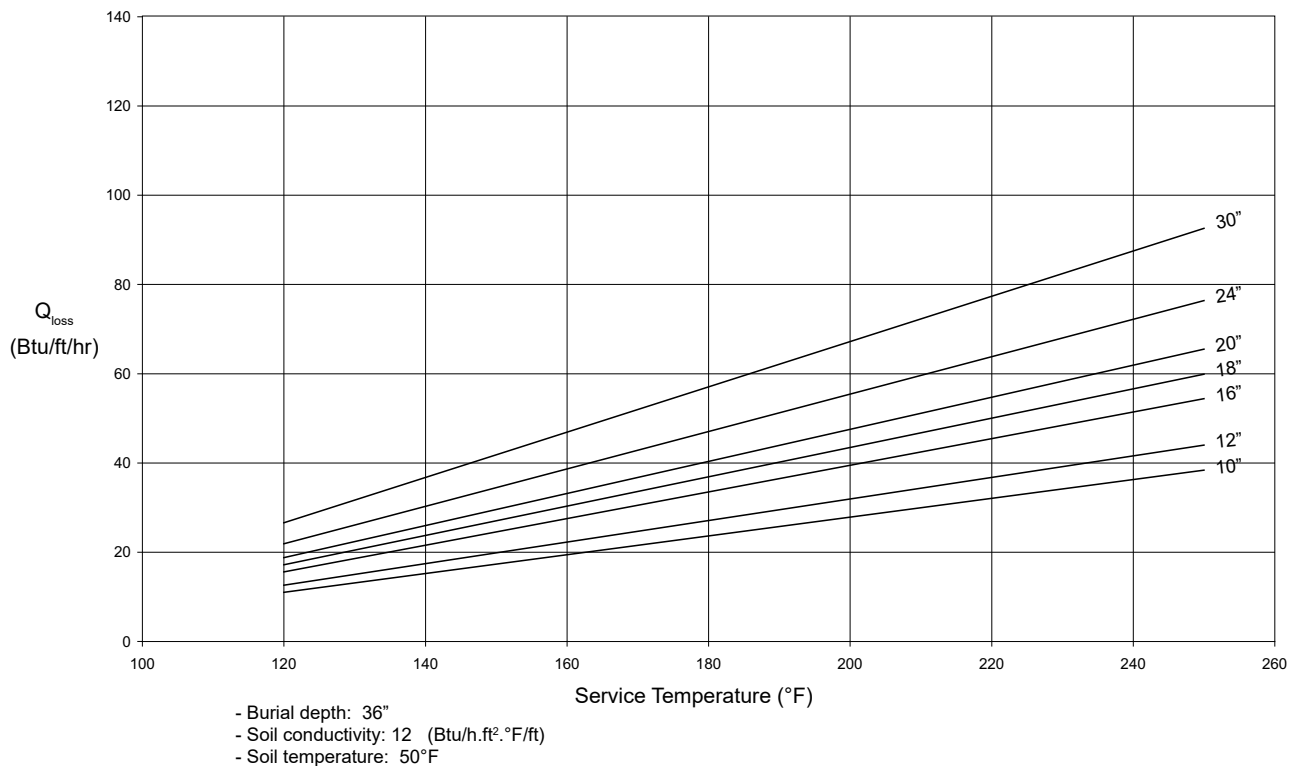

* Values are calculated using 3E Plus in accordance with ASTM C680 and are subject to the terms and limitations stated in the software. Actual heat loss may vary.



FERRO-THERM

Installation Manual

FTIM
7.201

GENERAL INSTALLATION INSTRUCTIONS

2.03.2021

INSTALLATION INSTRUCTIONS

UNLOADING & HANDLING

Lift joints from trucks. DO NOT DROP SHARP OR HEAVY OBJECTS ON INSULATED UNITS. DO NOT use chains or other devices which might puncture insulation jacket.

STORAGE

Pipe is stockpiled off the ground. Do not exceed a stacking height of 6'. Prevent dirt and debris from entering pipe. Fittings, joining materials, etc. must be stored indoors to protect them from freezing, overheating, moisture, or loss.

LAYING OF PIPE UNITS – TRENCHING

All sharp rocks, roots, and other abrasive material must be removed from the trench. The trench bed should be 6" of sand or backfill as specified by the engineer, providing a smooth and uniform stabilizing surface (sandbags may be used as a means to keep the pipe off the ground until backfilling is started). The trench width should provide a minimum of 6" from trench wall to jacket O.D. and a minimum of 6" between pipe units. Trench depths will be indicated on the contract drawing and in line with good construction practices. Trench depth should allow for a minimum cover of 24" on top of the insulated unit.

FIELD JOINING METHODS

Ferro-Therm piping and fittings shall be joined in the field using approved methods of welding for appropriate pipe.

FIELD ALTERATIONS

Pipe will be cut in the field, based on the appropriate field measurements for fabrication of loops, fittings, and/ or making manhole or wall entries unless the system is pre-engineered with piece mark sections and/ or with pre-fabricated/ pre-insulated fittings. If special short pieces are required, measure distance needed for field alteration and cut through unit with saw. Using factory insulated pipe as guide, cut back insulation and bevel pipe (simultaneously removing burrs, cuts, nicks, and scratches). Apply end seal to the clean, dry, exposed insulation surface, if required.

HYDROSTATIC TESTING

Anchor blocks shall be poured and cured, where shown on TPI drawings, prior to testing. Bleed all air from lines to eliminate possible incorrect readings. The hydrostatic pressure test shall be performed per the engineer's specification with a factory recommendation of one and one-half times the normal operating pressure for not less than two hours. Inspect all fittings, valves, and couplings at this time. *Appropriate safety precautions shall be taken to guard against possible injury to personnel in the event of a failure.*

FIELD JOINT & FITTING INSULATION

See Drawings furnished with job material.

BACKFILL FINAL

Before backfilling is started, the trench should be cleaned of any trench wall cave-ins and general trash, especially metal. Backfilling should be done with sand 6" below the casing to 6" above. Engineer-approved backfill may be used to fill the rest of the trench. This material should be free of rocks, roots, large clods, or anything that could cause damage to the jacket. Jacket should have a minimum of 2' cover.

*Thrust blocks are **NOT REQUIRED** on welded Ferro- Therm systems changes of direction.*

WHEELED OR TRACKED VEHICLES SHALL NOT BE USED FOR TAMPING!

SHIPPING & HANDLING INSTRUCTIONS

HANDLE COATED PIPE WITH EXTRA CARE! THIS PIPE CAN DAMAGE WHEN HANDLED, MOVED, OR STORED IMPROPERLY!

UPON RECEIPT OF MATERIALS

Make an overall inspection of the load, checking all bands and braces to see if they are intact. Also, check the load for shifting. If the load has shifted, or if the braces and bands are broken, examine each pipe for damage. **HAVE THE TRUCK DRIVER MAKE AN ITEMIZED NOTATION OF ANY DAMAGE ON THE DELIVERY RECEIPT AND HAVE IT SIGNED BY THE DRIVER.**

CHECK PACKING LIST

Compare materials received with those listed on the packing list. Count all pipe and boxes. **NOTE ANY SHORTAGES ON DRIVER'S DELIVERY RECEIPT.**

CHECK BOXES

Open all boxes and inspect for damages, shortages, and correct size. **REPORT ANY DISCREPANCIES WITHIN 30 DAYS AFTER RECEIPT.**

CLAIMS FOR DAMAGES

Claims for damages in transit or lost goods must be made within 30 days. The filing of any claim is the Purchaser's Responsibility. Thermacor will file any claim on Purchaser's behalf upon receipt of the following:

1. Written authority to file such a claim.
2. Written notice of loss or damage (signed and noted Bill of Lading) by truck driver or carrier freight agent.

UNLOADING PIPE

Pipe may be unloaded by hand or with fork lifts*, cherry pickers, or cranes. **DO NOT HOOK** pipe ends. Minimum 4" wide straps or slings should be used.

*Fork Lift – When using Fork Lift, wide tines or a large surface covering the fork tines must be used to prevent coating damage. Fork Lift must be able to handle the weight of the insulated pipe length.

PIPE STOCKPILING

Pipe should be stored on level ground, elevated to be as dry as possible, and in such a way that the pipe ends do not lie in water or on the ground. To prevent deformation of the jacket and insulation due to the weight of the pipe, place a series of supports (3 for 20' or 5 for 40') of ample size generally constructed from 2" x 4"s under the pipe as shown below. Supports should increase in width as weight load increases so that the top supports of a fully loaded stockpile should be approximately 10" wide, gradually increasing to the bottom level, approximately 18" wide. Pipe can be pyramided (within reasonable and safe limits) approximately 6' high after a properly braced or chocked base is formed. Pipe stored outside for long periods of time can be covered with blue mesh tarpaulin (plywood can also be used). **Do not prevent airflow as jacket can be deformed from heat buildup.**

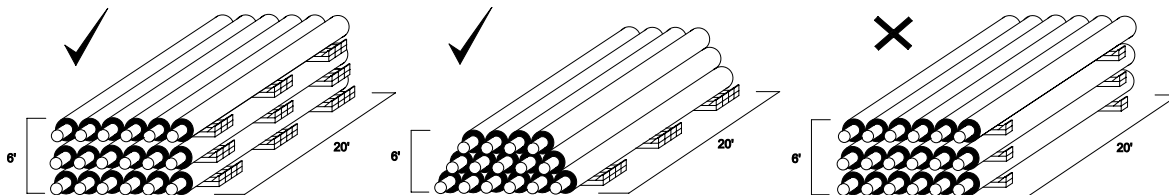

BE VERY CAREFUL NOT TO DROP THE PIPE!

NOTE: Thermacor does not approve of the practice of installing pipe and fittings, and backfilling the pipe before testing. Thermacor will not allow or pay claims for charges which arise in locating and digging up leaks regardless of cause.

* NOTE:
ON SOME CONFIGURATIONS, A THROATED
FITTING COVER IS REQUIRED.

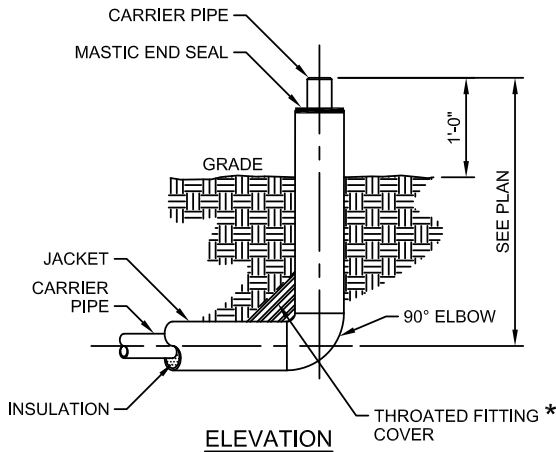

RISER DETAIL

SCALE: NONE

* NOTE:
ON SOME CONFIGURATIONS, A THROATED
FITTING COVER IS REQUIRED.

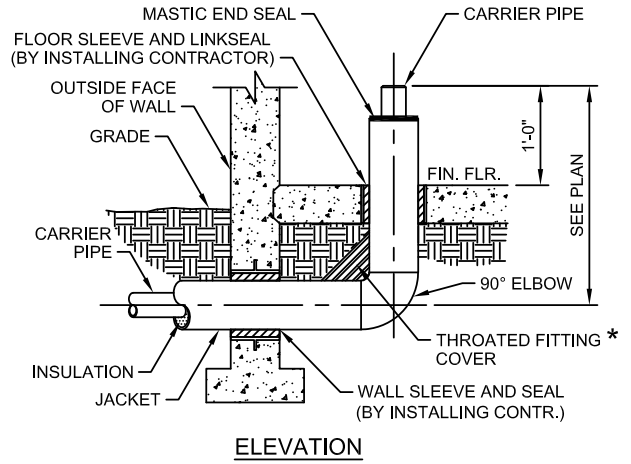

BUILDING RISER DETAIL

SCALE: NONE

* NOTE:
STEEL WALL RING WILL INCREASE OUTSIDE
DIAMETER OF HDPE JACKET BY 1/2".

** NOTE:
ON SOME CONFIGURATIONS, A THROATED
FITTING COVER IS REQUIRED.

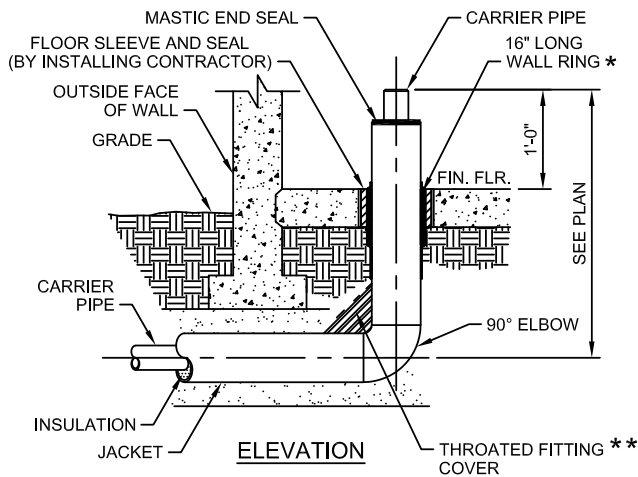

BUILDING RISER DETAIL

SCALE: NONE

* NOTE:
ON SOME CONFIGURATIONS, A THROATED
FITTING COVER IS REQUIRED.

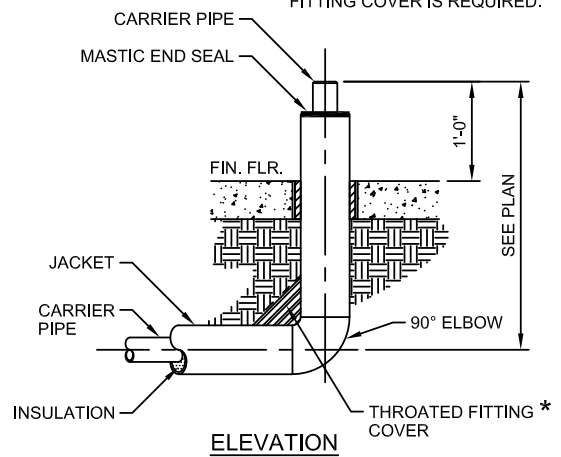

RISER DETAIL

SCALE: NONE

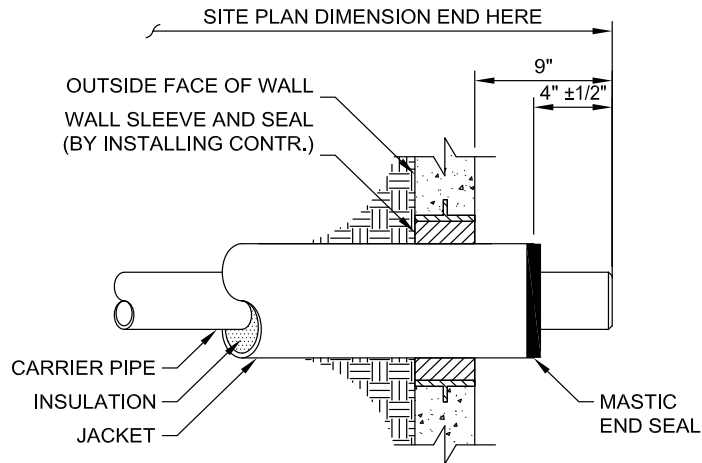

GENERAL NOTES:

- (1) FOR SYSTEMS WHICH ARE ANCHORED, A MECHANICAL COMPRESSIVE SEAL ASSEMBLY CAN BE UTILIZED FOR WATERPROOFING THE WALL PENETRATION.
- (2) IF EXPANSION THRU THE WALL IS ANTICIPATED, WE RECOMMEND THE FOLLOWING SEALING MECHANISM:
 - A. WRAP THE EXTERIOR OF THE JACKET WITH AN OILED OAKUM MATERIAL FROM THE INSIDE OF THE WALL TO ABOUT HALFWAY THRU THE WALL.
 - B. WRAP THE EXTERIOR OF THE JACKET WITH ARMAFLEX MATERIAL TO THE OUTER WALL.
 - C. COAT THE ARMAFLEX WITH A BITUMASTIC SEALANT.

WALL PENETRATION DETAIL

SCALE: NONE

1. PLACE BOLSTER PADS AGAINST JACKET AND CURVE AROUND ELBOW AS SHOWN. HOLD IN PLACE BY ATTACHING PADS TO JACKET WITH DUCT TAPE OR EQUIVALENT ON TOP AND BEDDING SAND ON THE BOTTOM. BE CERTAIN THAT THE BOLSTER PADS FITS SNUG TO JACKET.

JACKET SIZE (OD)	PAD HEIGHTS	DUAL PADS	SINGLE PADS
JACKET OD < 10"	7"	BOL-1	BOL-5
10" ≤ JACKET OD < 16"	13"	BOL-2	BOL-6
16" ≤ JACKET OD < 22"	17"	BOL-3	BOL-7
JACKET OD ≥ 22"	25"	BOL-4	BOL-8

*** NOTE:**
DUCT TAPE TO BE 1'-0" ON CENTERS.

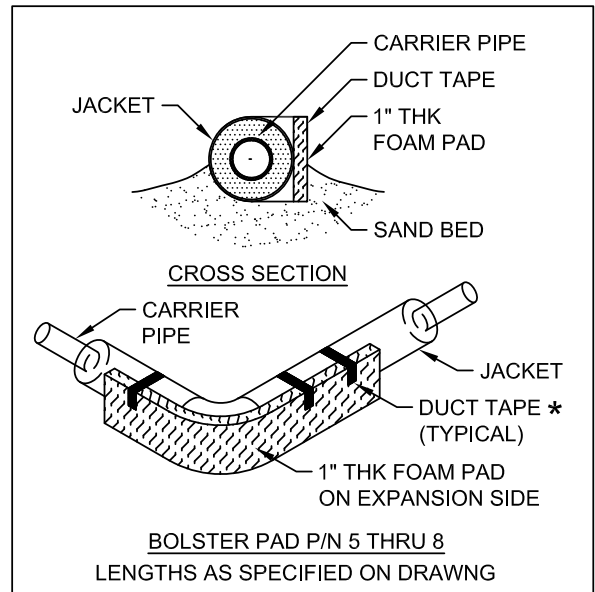
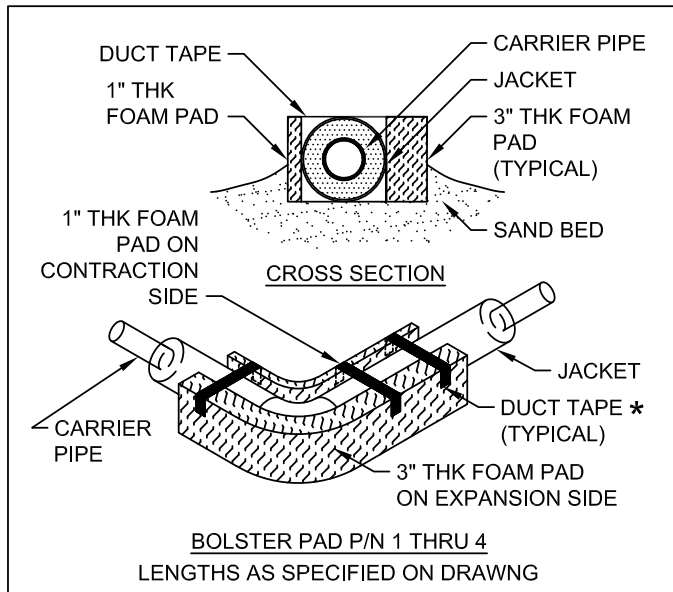

BOLSTER PAD DETAIL

SCALE: NONE

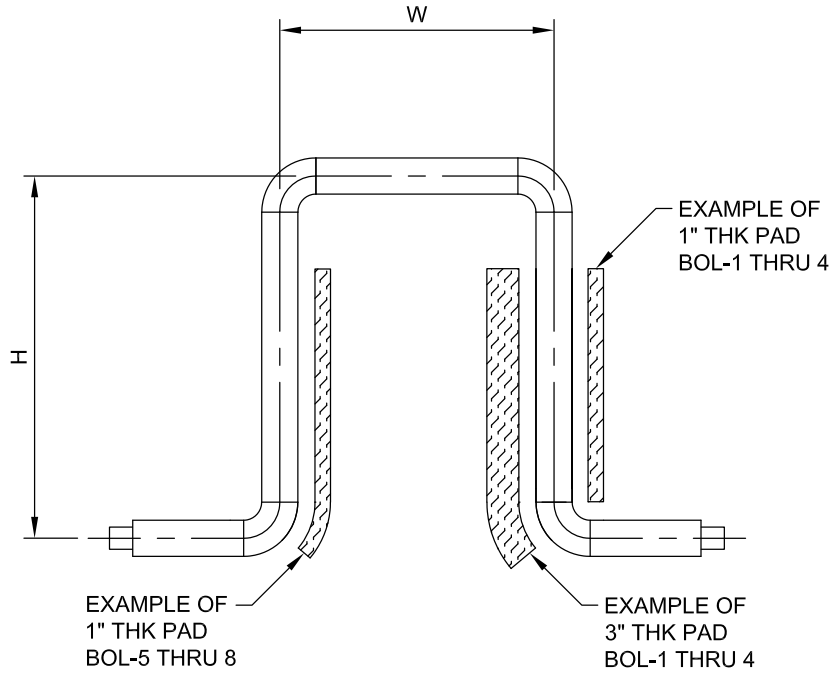

EXPANSION LOOP DETAIL

SCALE: NONE

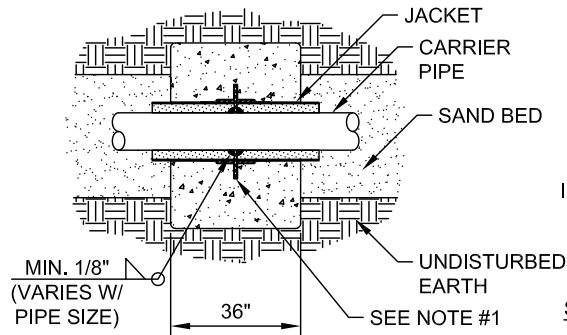
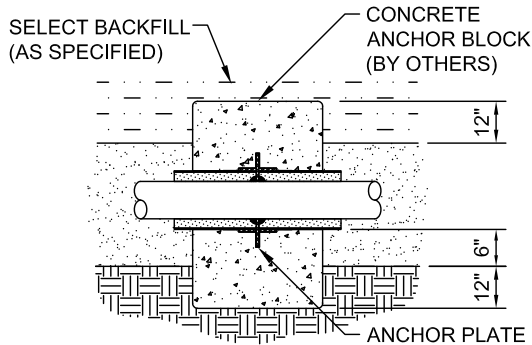
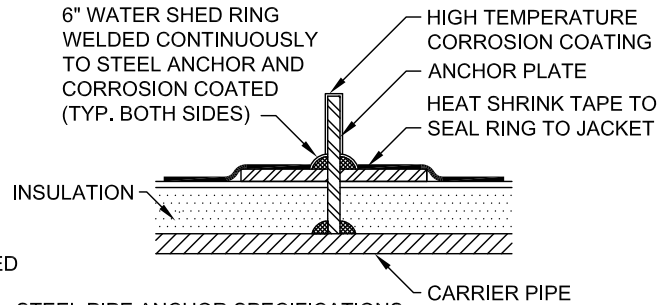
TOP VIEW

SIDE VIEW

STEEL PIPE ANCHOR SPECIFICATIONS

1. STEEL ANCHOR PLATE AND WELDED RINGS FURNISHED BY THERMACOR, ANCHOR PLATE SHALL MEET ASTM A36 AND ON ALL SIZES SHALL BE 1/2" THICK. ANCHOR PLATE SHALL EXTEND 2-1/2" BEYOND THE CASING DIAMETER ON ALL SIDES. ANCHOR PLATE SHALL BE CORROSION COATED WITH A HIGH TEMPERATURE COATING MATERIAL AFTER WATERSHED RINGS HAVE BEEN SEALED TO CASING BY HEAT SHRINK TAPE.
2. ANCHOR ASSEMBLY SHALL BE POURED IN A CONCRETE BLOCK BY THE CONTRACTOR IN THE FIELD, (MINIMUM 3000 psi) GENERALLY, THE ANCHOR BLOCK EXTENDS A MINIMUM OF 12" IN ALL DIRECTIONS BEYOND THE ANCHOR O.D. AND HAS A OVERALL LENGTH OF 36". THE JOB SITE CONDITIONS SHALL BE THE FINAL DETERMINING FACTOR FOR ANCHOR BLOCK SIZING.
3. DEPENDING ON ANCHOR BLOCK SIZE, STEEL REINFORCEMENT BARS MAY BE REQUIRED.

NOTE:

IT IS THE RESPONSIBILITY OF THE **ENGINEER OF RECORD** TO DESIGN THE ANCHOR BLOCKS APPROPRIATELY.

ANCHOR DETAIL

SCALE: NONE

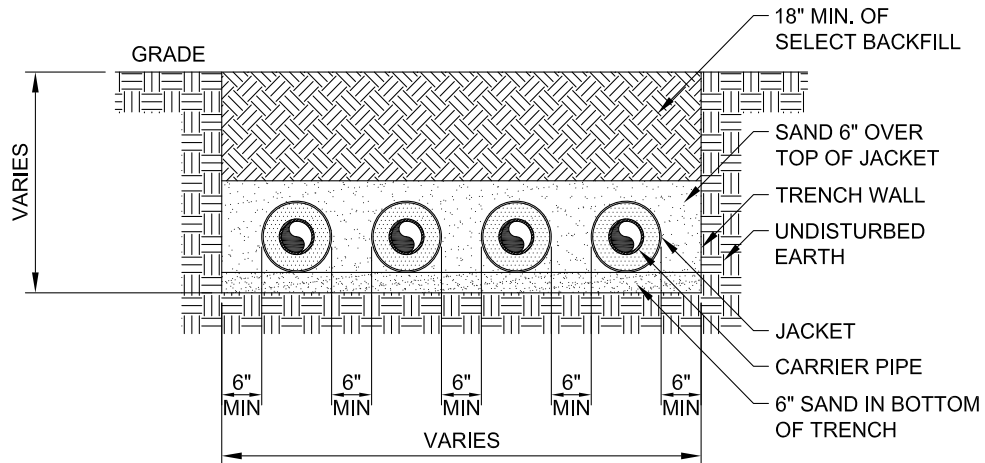

TRENCH DETAIL

SCALE: NONE