



# STEEL-THERM

## Specification Guide

STSG  
11.101

STANDARD SPECIFICATION

2.03.2021

*Pre-insulated Steel Piping Systems suitable for Chilled Water, Heating Water, Domestic Hot Water.*

### Part 1 - General

**1.1 Pre-insulated Piping** - Furnish a complete system of factory pre-insulated steel piping for the specified service. All pre-insulated pipe, fittings, insulating materials, and technical support shall be provided by the Pre-insulated Piping System manufacturer.

**1.2 The system** shall be **STEEL-THERM** manufactured by **Thermacor Process Inc.** of Fort Worth, Texas.

### Part 2 - Products

**2.1 Carrier pipe** shall be steel ASTM A-53, Grade B., ERW (Type E) or seamless (Type S), standard weight for sizes 2" and larger, and shall be ASTM A-106/ A-53, Grade F (Type F) seamless, standard weight for sizes 1-1/2" and smaller (Std. Wt. is the same as Sch. 40 through 10"). All carbon steel pipe shall have ends cut square and beveled for gasket coupling joints.

**2.2 Insulation** shall be polyurethane foam either spray applied or injected with one shot into the annular space between carrier pipe and jacket, and shall be bonded to both. Insulation shall be rigid, 90-95% closed cell polyurethane with a 2.0 to 3.0 lbs. per cubic foot density and coefficient of thermal conductivity (K- Factor) of 0.18 and shall conform to ASTM C-591. Maximum operating temperature shall not exceed 250°F. Insulation thickness shall be specified by calling out appropriate carrier pipe and jacket size combinations as listed on drawing STSG 11.103.

**2.3 Jacketing material** shall be extruded, black, high density polyethylene (HDPE), having a wall thickness not less than 100 mils for jacket sizes less than or equal to 12", 125 mils for jacket sizes greater than 12" to 24", and 150 mils for jacket sizes larger than 24". No tape jacket allowed. The inner surface of the HDPE jacket shall be oxidized by means of corona treatment, flame treatment (patent pending), or other approved methods. This will ensure a secure bond between the jacket and foam insulation preventing any ingress of water at the jacket/ foam interface.

**2.4 Straight run joints** are joined using ductile iron couplings with EPDM gaskets. (Joints are insulated with flexible polyurethane and may be jacketed with a split sleeve and sealed with heat shrink tape to prevent the ingress of moisture or debris.)

**2.5 Fittings** shall be butt-welded steel. The fittings are uninsulated and anchored with concrete thrust blocks. Fittings are thrust blocked at all changes of direction and pipe size changes. Steel fittings are to be coated with a thick layer (1/16") of mastic.

### Part 3 - Execution

**3.1 Underground systems** shall be buried in a trench of not less than two feet deeper than the top of the pipe and not less than eighteen inches wider than the combined O.D. of all piping systems. A minimum thickness of 24 inches of compacted backfill over the top of the pipe will meet H-20 highway loading.

**3.2 Trench bottom** shall have a minimum of 6" of sand, as approved by the engineer, as a cushion for the piping. Pipe and fittings shall be laid sequentially, field cutting the pipe as necessary per the manufacturer's installation instructions. At least the center 75% of each section of pre-insulated pipe shall be covered (approximately one foot of cover per 100 psi of test pressure) with select backfill material. All fittings shall be suitably thrust blocked before attempting any pressure tests of the system.

**3.3 A hydrostatic pressure test** of the carrier pipe shall be performed per the engineer's specification with a factory recommendation of one and one-half times the normal system operating pressure for not less than two hours. Care shall be taken to ensure all trapped air is removed from the system prior to the test. *Appropriate safety precautions shall be taken to guard against possible injury to personnel in the event of a failure.*

(Continued)



# STEEL-THERM

## Specification Guide

STANDARD SPECIFICATION

STSG  
**11.102**

2.03.2021

**3.4 Field service**, if required by project specifications, will be provided by a certified manufacturer's representative or company field service technician. The technician will be available at the job to check unloading, storing, and handling of pipe, joint installation, pressure testing, and backfilling techniques. This service will be added into the cost as part of the project technical services required by the pre-insulated pipe manufacturer.

**Carrier Pipe:**

- d ≥ 2" - A53 ERW Grade B, Std. Wt. Black Steel
- d < 2" - A106 SML, Std. Wt. Black Steel
- Seamless and Schedule 80 pipe available for all sizes
- Std. Wt. is the same as Schedule 40 for all sizes thru 10"
- XS is the same as Schedule 80 for all sizes thru 8"
- Ductile Iron Couplings

**Jacketing Material:**

High Density Polyethylene (HDPE)

**Insulation:**

Polyurethane Foam

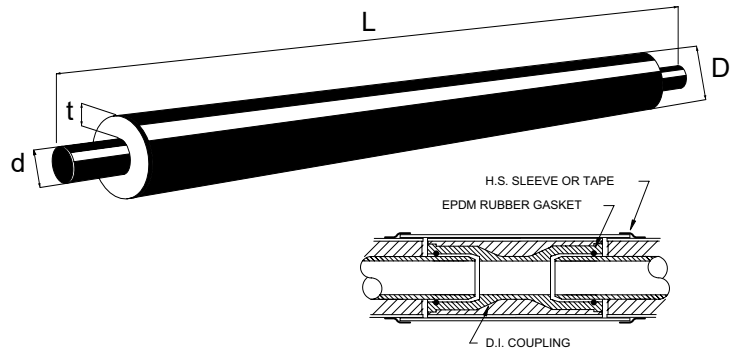

| Pipe Size | Jacket Size | Standard Length L | Insulation Thickness t | External Diameter D | Weight Per Foot (lbs.) |
|-----------|-------------|-------------------|------------------------|---------------------|------------------------|
| 1-1/2"    | 5.4"        | 20'               | 1.65"                  | 5.40"               | 4.21                   |
| 2"        | 5.4"        | 40'               | 1.41"                  | 5.40"               | 5.11                   |
| 2-1/2"    | 6.7"        | 40'               | 1.80"                  | 6.68"               | 7.73                   |
| 3"        | 6.7"        | 40'               | 1.49"                  | 6.68"               | 9.44                   |
| 4"        | 8.7"        | 40'               | 1.99"                  | 8.68"               | 13.48                  |
| 6"        | 10.9"       | 40'               | 2.01"                  | 10.85"              | 22.79                  |
| 8"        | 12.9"       | 40'               | 1.99"                  | 12.85"              | 32.96                  |
| 10"       | 14.1"       | 40'               | 1.56"                  | 14.12"              | 45.64                  |
| 12"       | 16.1"       | 40'               | 1.57"                  | 16.14"              | 56.01                  |

\* Other sizes are available



# STEEL-THERM

## Specification Guide

STSG  
11.104

HEAT LOSS DIAGRAM (1" - 8" PIPE)

2.03.2021

### HEAT LOSS FOR 1" OF POLYURETHANE FOAM\*

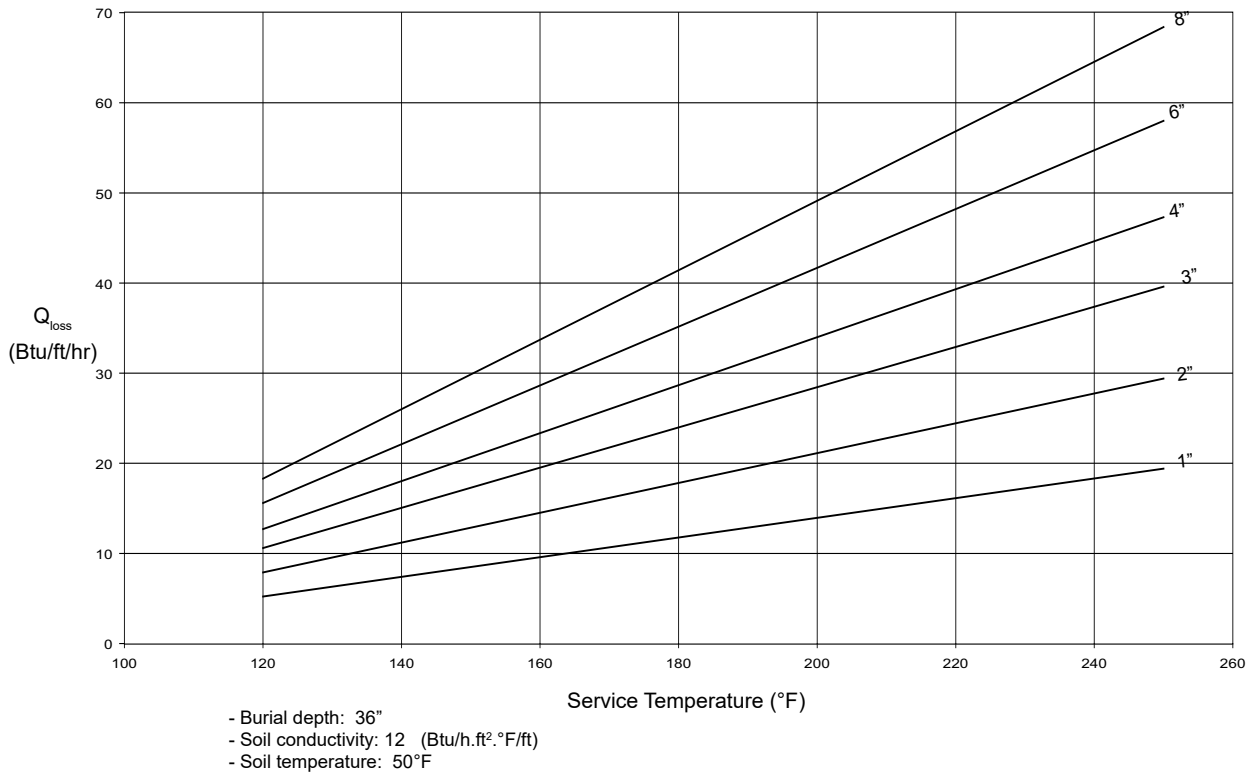

### HEAT LOSS FOR 2" OF POLYURETHANE FOAM\*

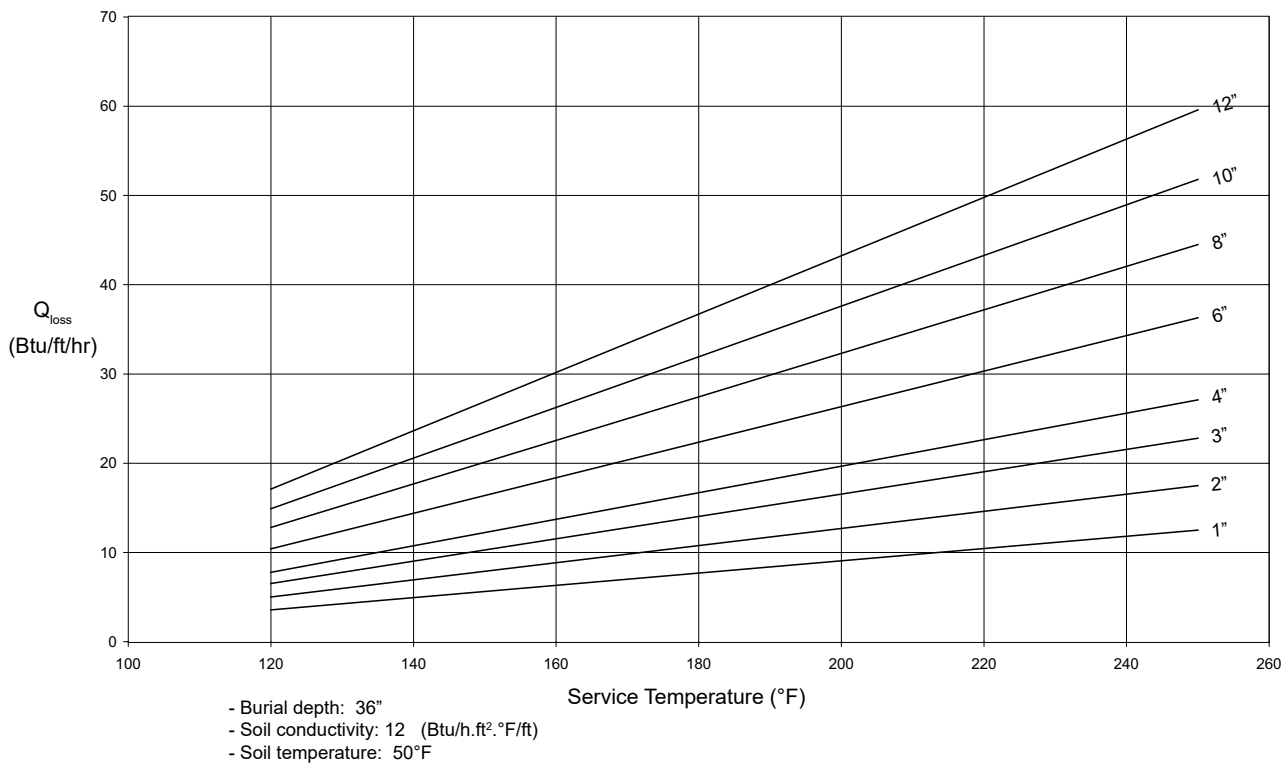

\* Values are calculated using 3E Plus in accordance with ASTM C680 and are subject to the terms and limitations stated in the software. Actual heat loss may vary.